

DETAIL-1 FOOTING DETAIL (TYP) 3/4" = 1'-0"

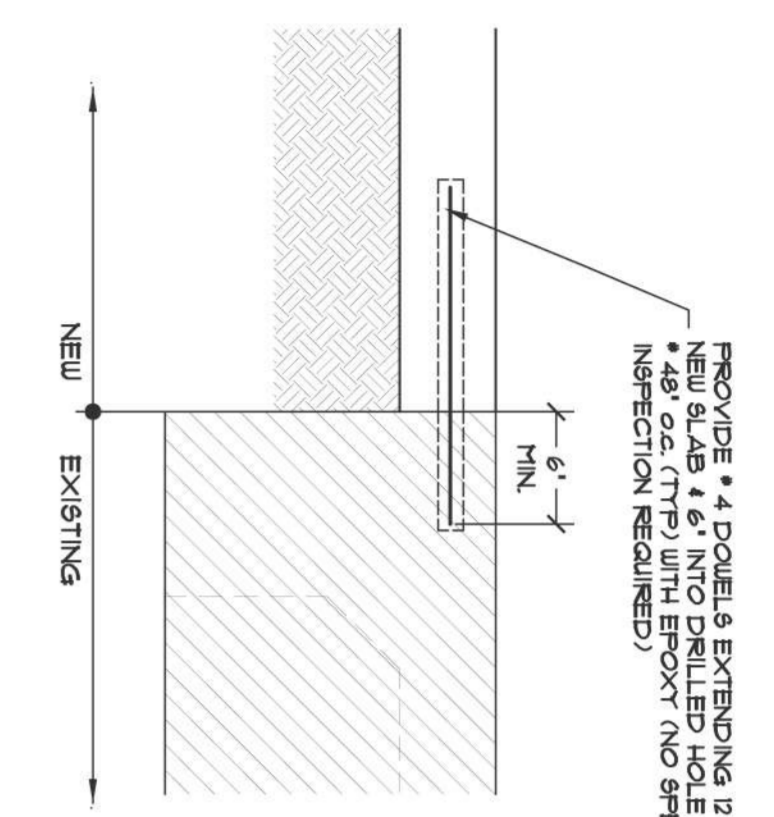

DETAIL-2 (NEW SLAB W/ E) FOOTING 1" = 1'-0"

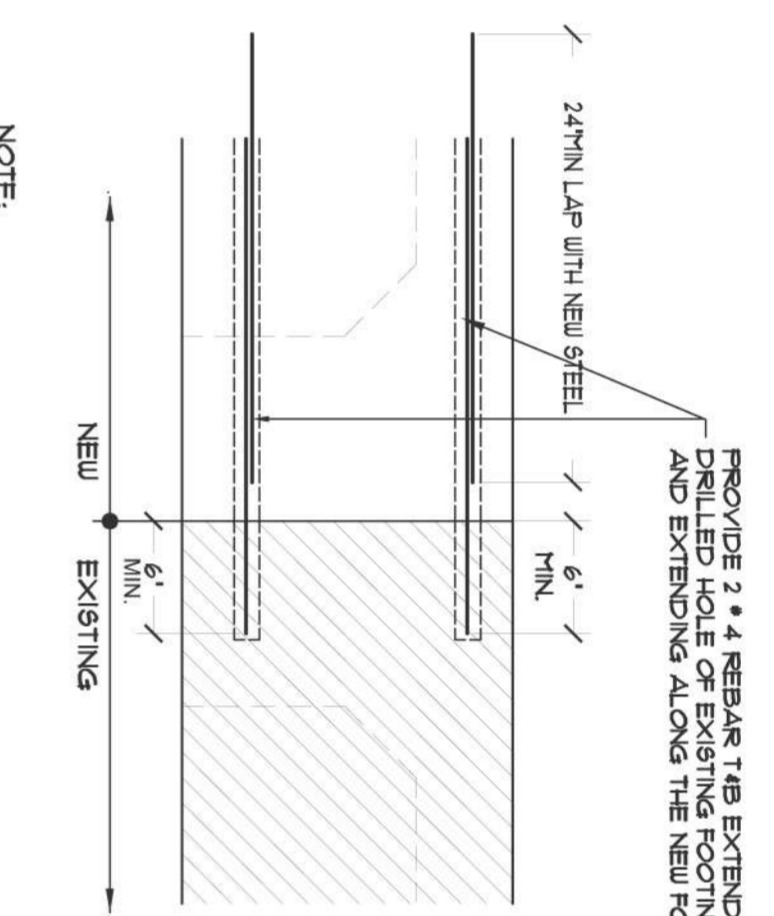

DETAIL-3 (NEW FOOTING W/ E) FOOTING 1" = 1'-0"

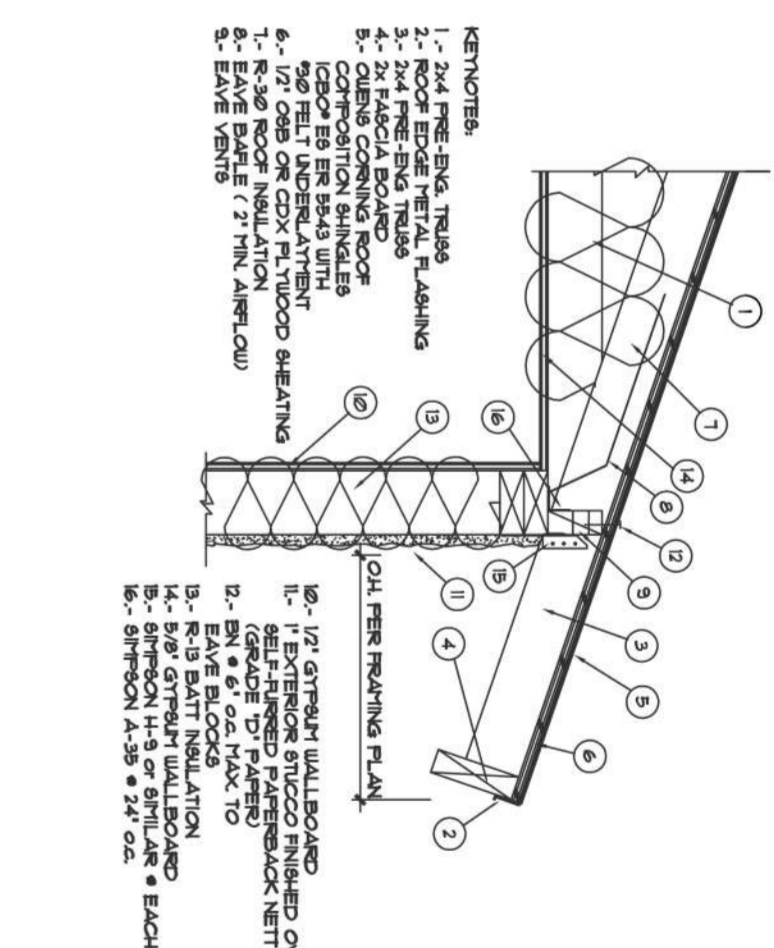

DETAIL-4 EAVE DETAIL (TYP) 1" = 1'-0"

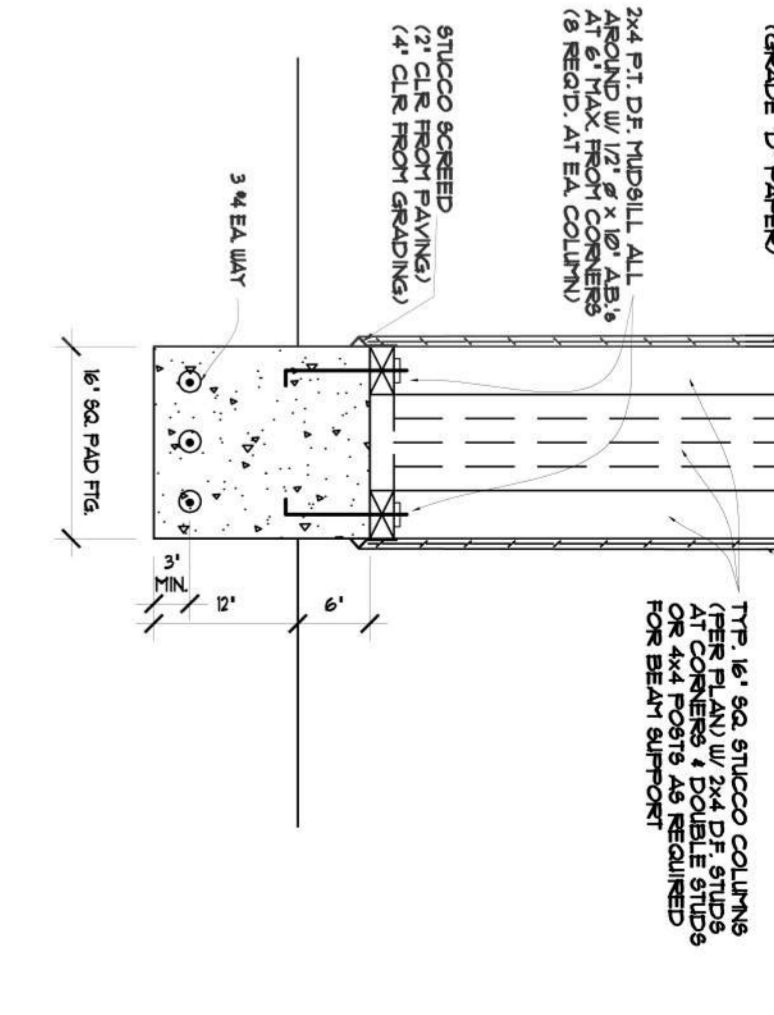

DETAIL-5 COLUMN-FOOTING DETAIL 1-1/2" = 1'-0"

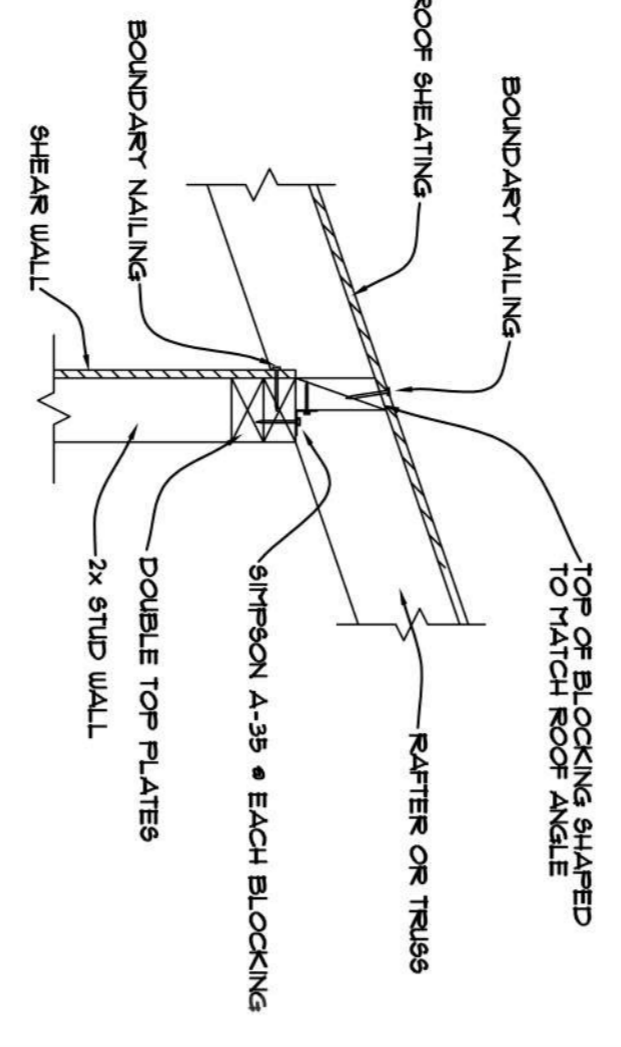

DETAIL-6 SHEAR WALL CONNECTION @ EAVE N.T.S.

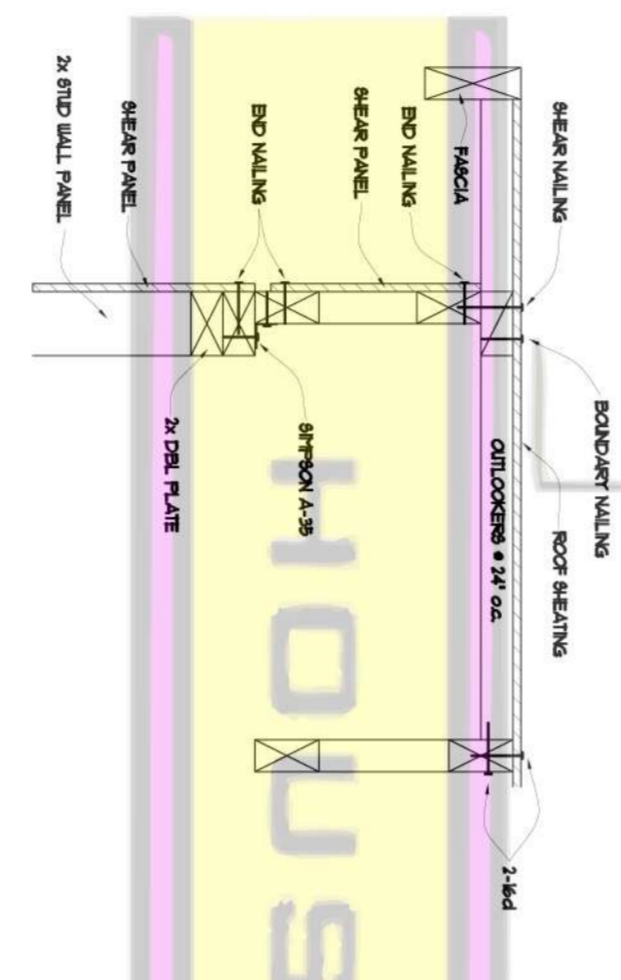

DETAIL-7 GABLE END TRUSS OVER SHEAR WALL 1" = 1'-0"

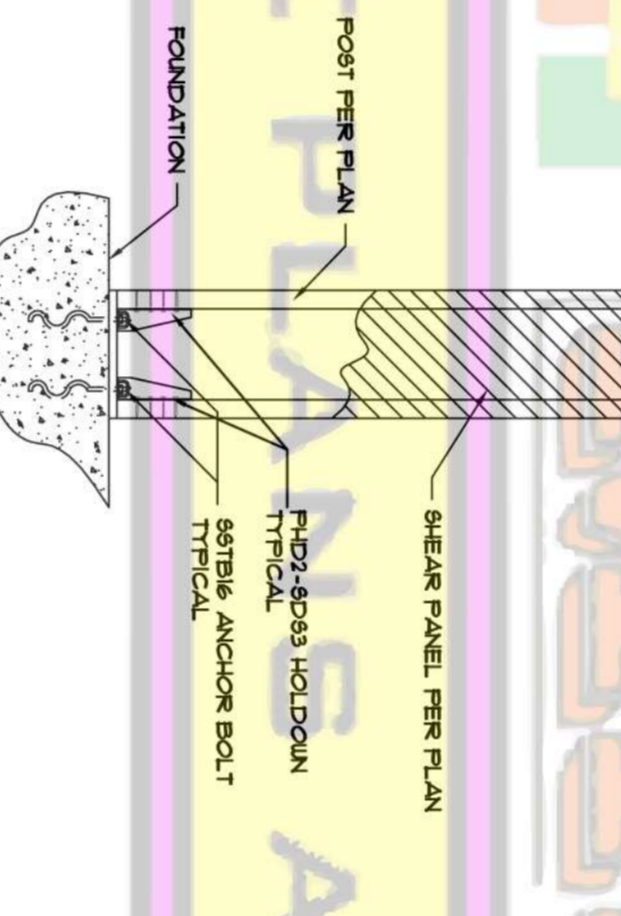

DETAIL-8 SHEAR PANEL DETAIL N.T.S.

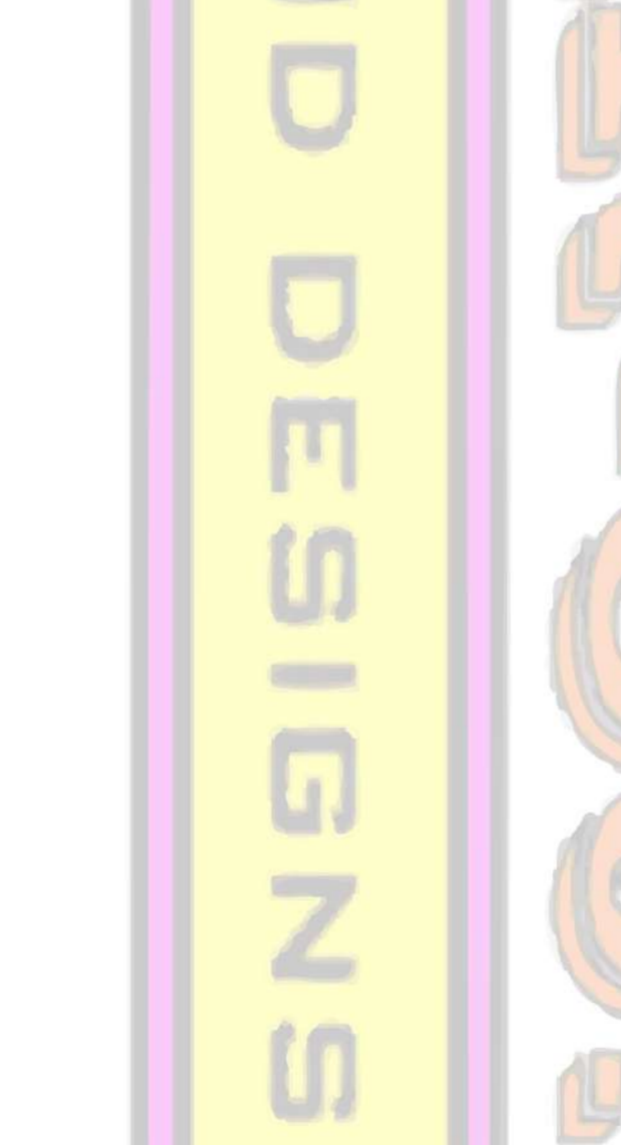

DETAIL-9 SHEAR WALL SCHEDULE - CBC 1001 N.T.S.

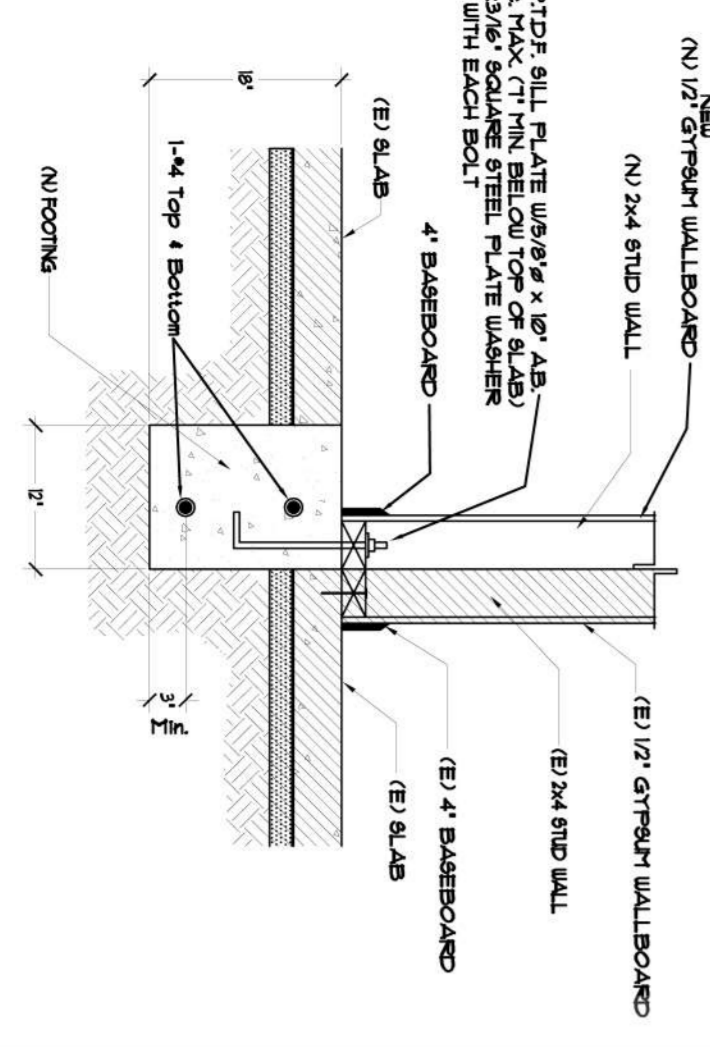

DETAIL-10 (N) FOOTING @ (E) CONCRETE SLAB N.T.S.

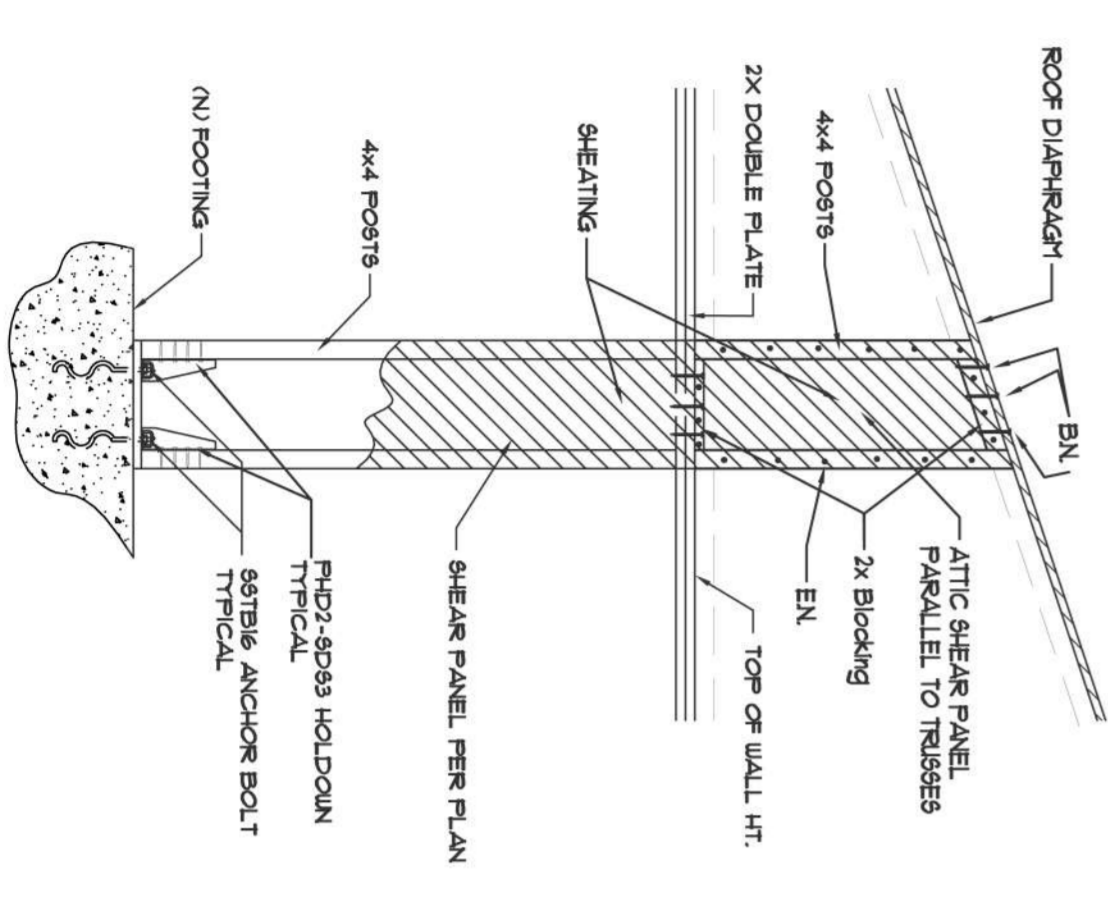

DETAIL-11 ATTIC SHEAR PANEL PARALLEL TO TRUSSES N.T.S.

DISEÑO DIBUJO Y CONSTRUCTION
 Dibujo de planos arquitectonicos
 Permisos para construcción
 Ampliación de cuartos y patios
 Marco A. Laureano
 760.805.2358
 760.941.2678
 LICENSE: 16964

MARCO'S HOUSE PLANS & DESIGN
 Architectural CAD drafting
 Building permits
 Room and patio additions
 Marco A. Laureano
 760.805.2358
 760.941.2678
 LICENSE: 16964

OWNER:
MR. & MRS. GAMEZ
 XXXX ELBERT TER. HOME: 000-000-0000
 MIRAMEBA, CA. 92126 CELL: 000-000-0000

PROJECT NAME:
PROPOSED ROOM ADDITION
 XXXX ELBERT TER. MIRAMEBA, CA. 92126

REVISIONS:
 DATE: **OCTOBER / 2025**
 SCALE: **AS SPECIFIED**
 PLANS DRAWN & PREPARED BY:
MARCO A. LAUREANO
 JOB: **ROOM ADDITION**
 SHEET: **A-4**
 OF SHEET: **6**