

NOTE:  
1. REFER TO EMBEDMENT SCHEDULE ON DETAIL 4  
2. FOUNDATION AND STEM WALL (SEE AND REINFORCEMENT) BY OTHERS

**SSW ANCHORAGE (SLAB ON GRADE)**

1

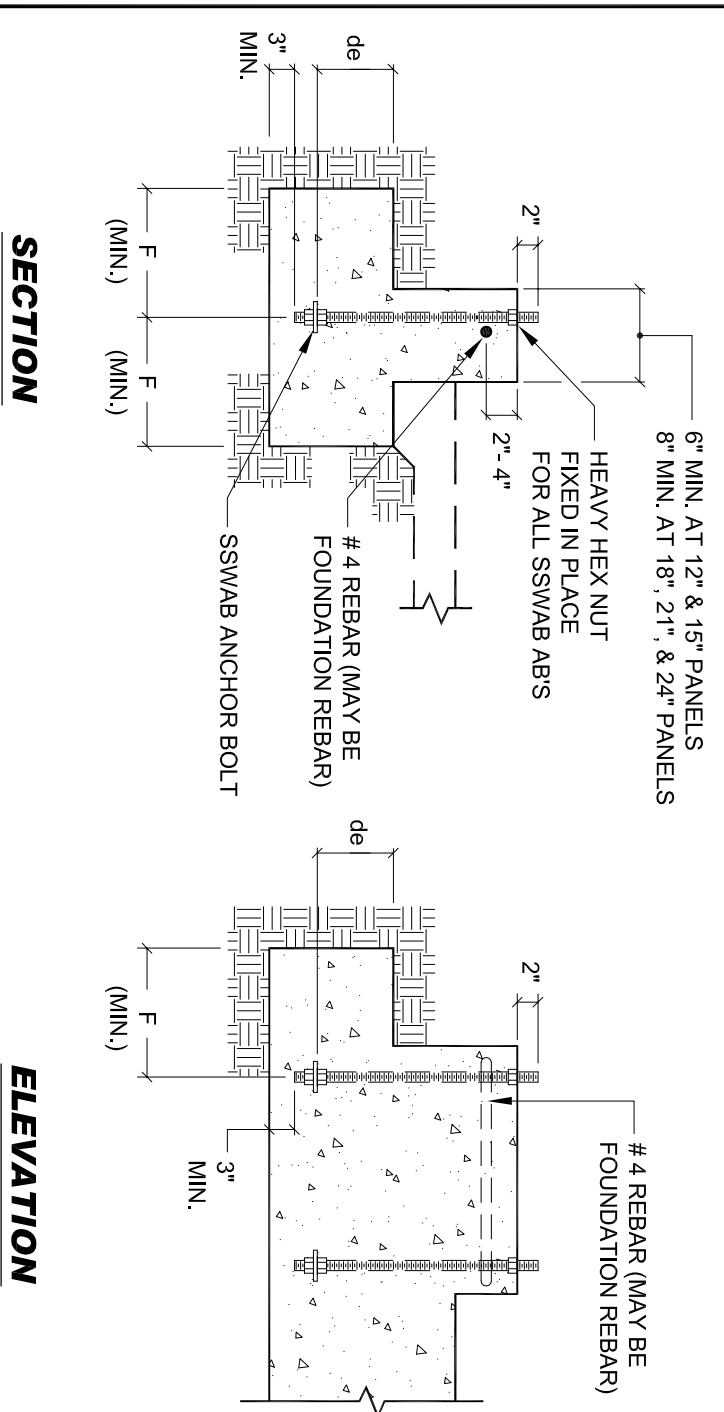

NOTE:  
1. REFER TO EMBEDMENT SCHEDULE ON DETAIL 4  
2. FOUNDATION AND STEM WALL(SIZE AND REINFORCEMENT) BY OTHERS

**SSW ANCHORAGE (CURB / STEM WALL)**

2

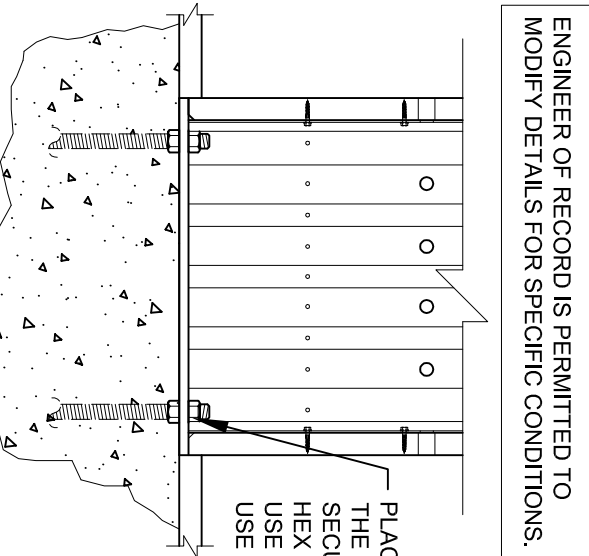

ENGINEER OF RECORD IS PERMITTED TO MODIFY DETAILS FOR SPECIFIC CONDITIONS.

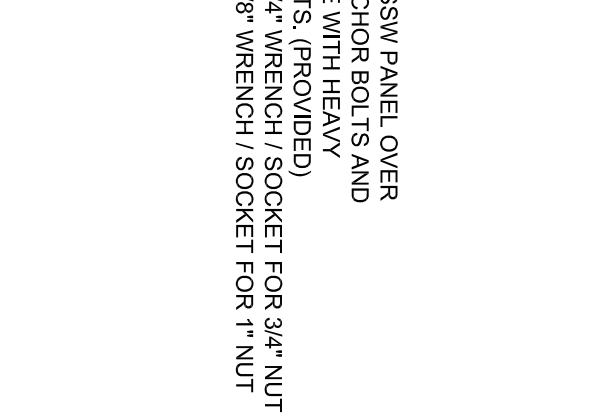

ENGINEER OF RECORD IS PERMITTED TO MODIFY DETAILS FOR SPECIFIC CONDITIONS.

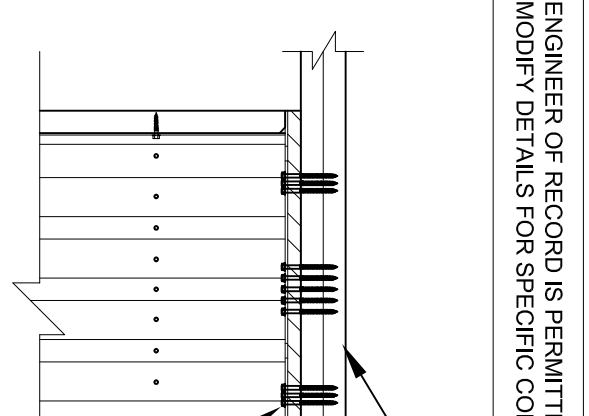

ENGINEER OF RECORD IS PERMITTED TO MODIFY DETAILS FOR SPECIFIC CONDITIONS.

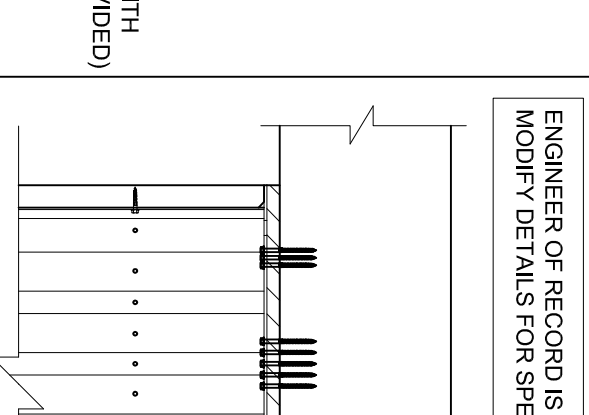
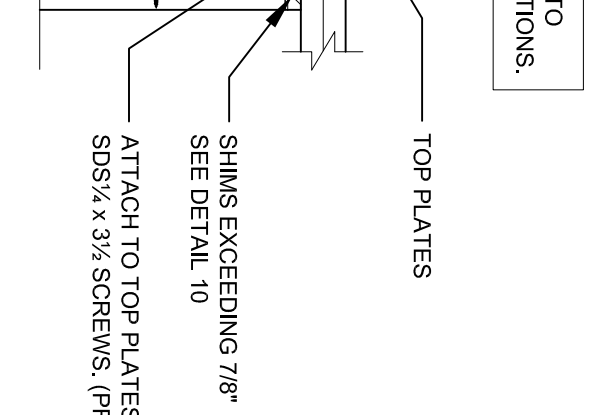

**SSW BASE PLATE CONNECTION**

**SSW TOP PLATE CONNECTION**

**SSW HEADER CONNECTION**

**SSW GARAGE WALL OPTION 1**

**SSW GARAGE WALL OPTION 2**

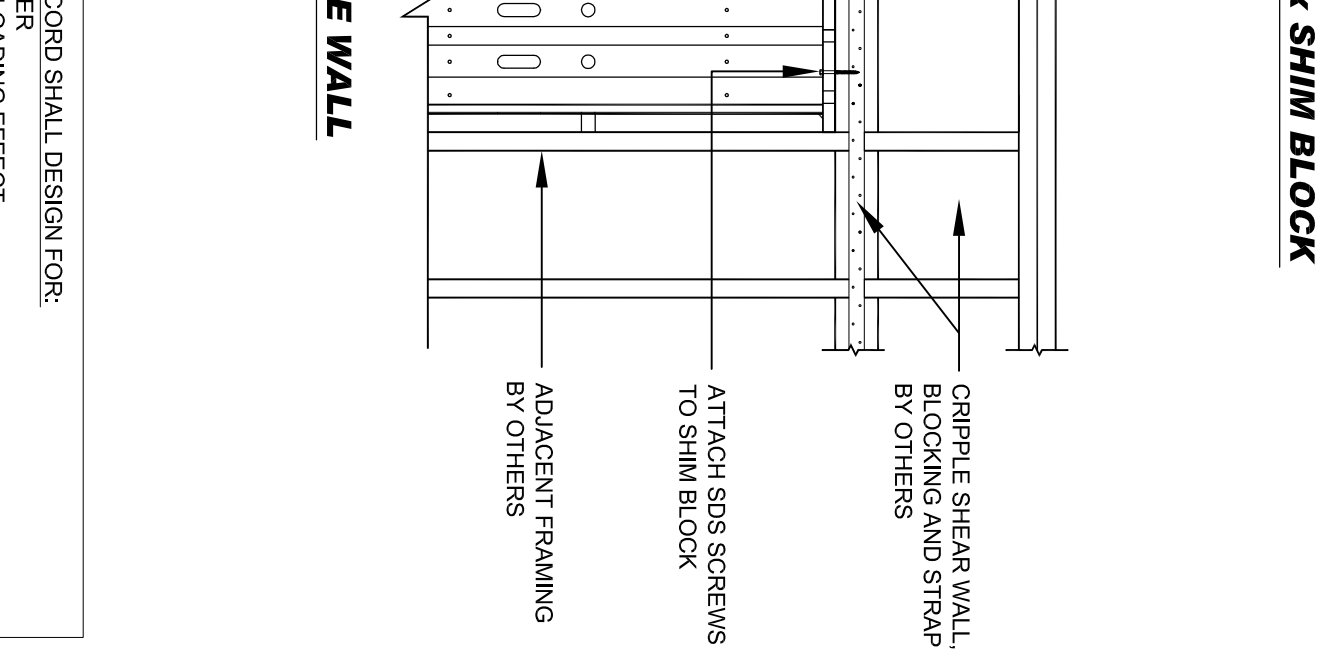
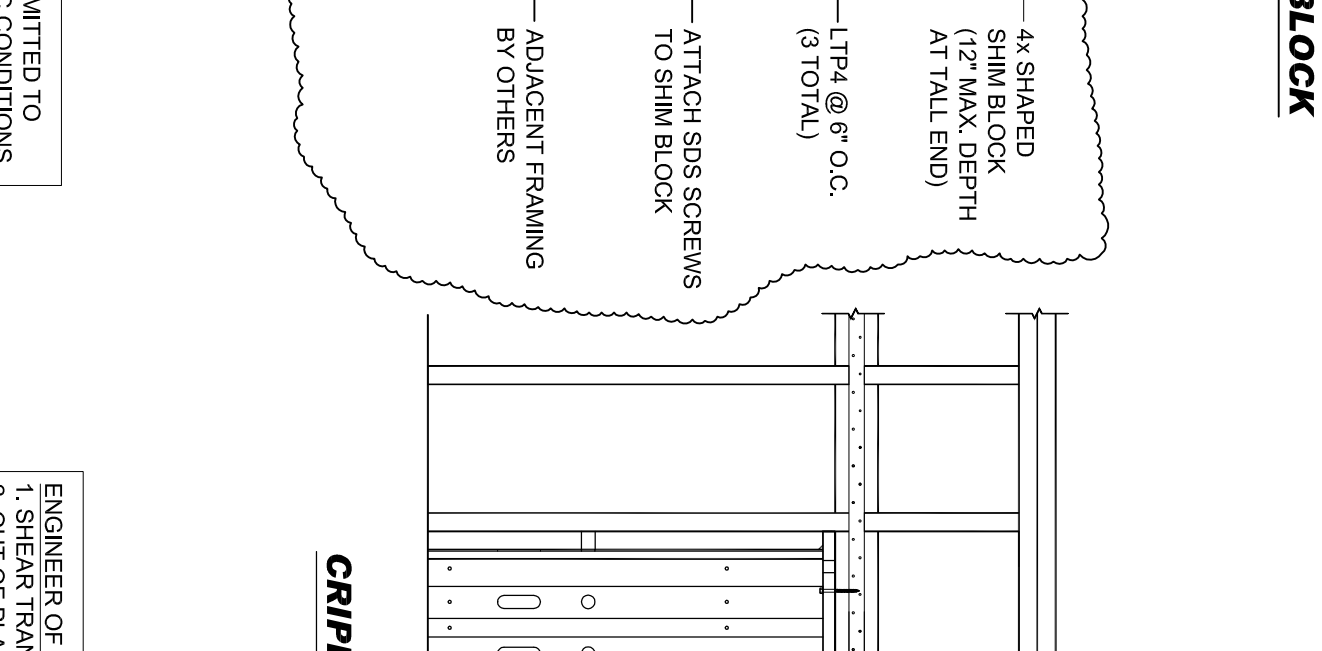
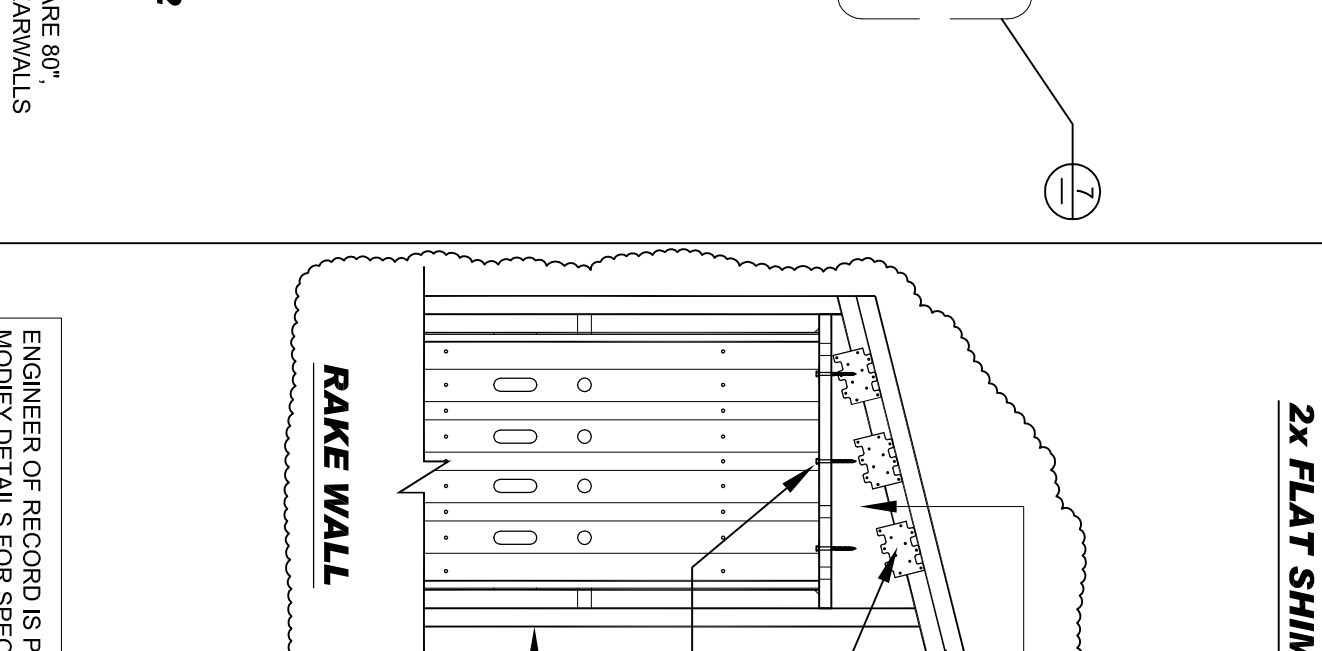
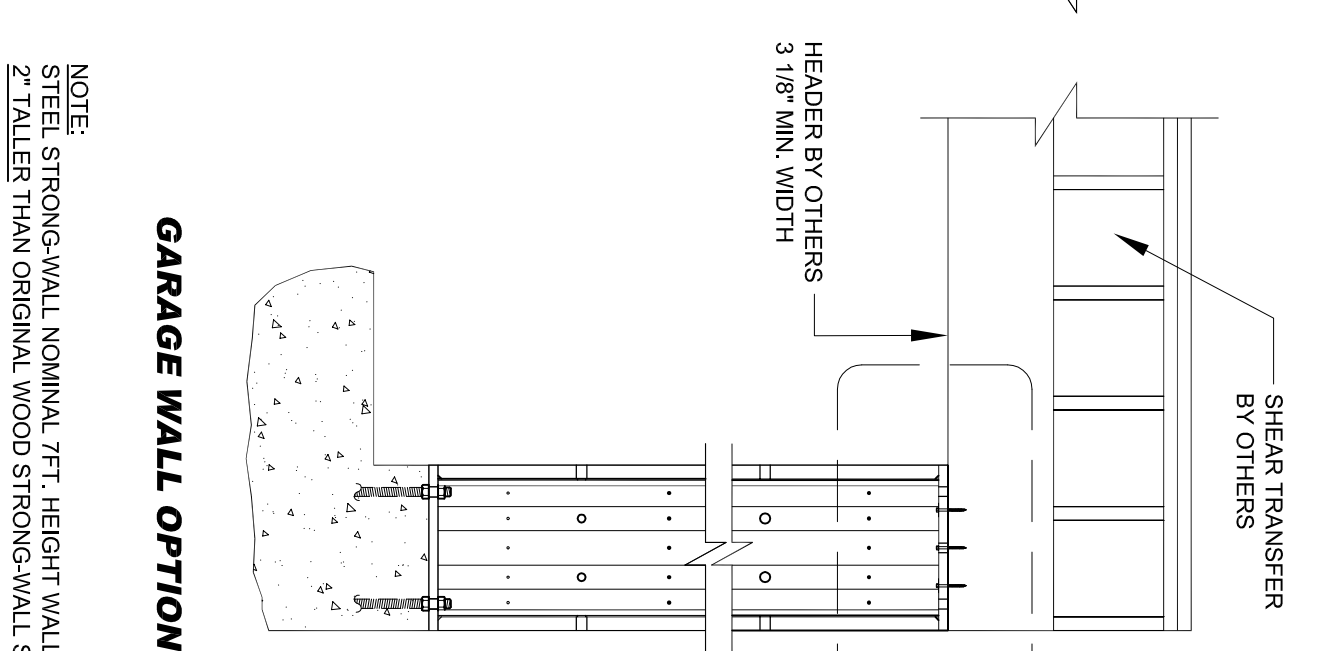
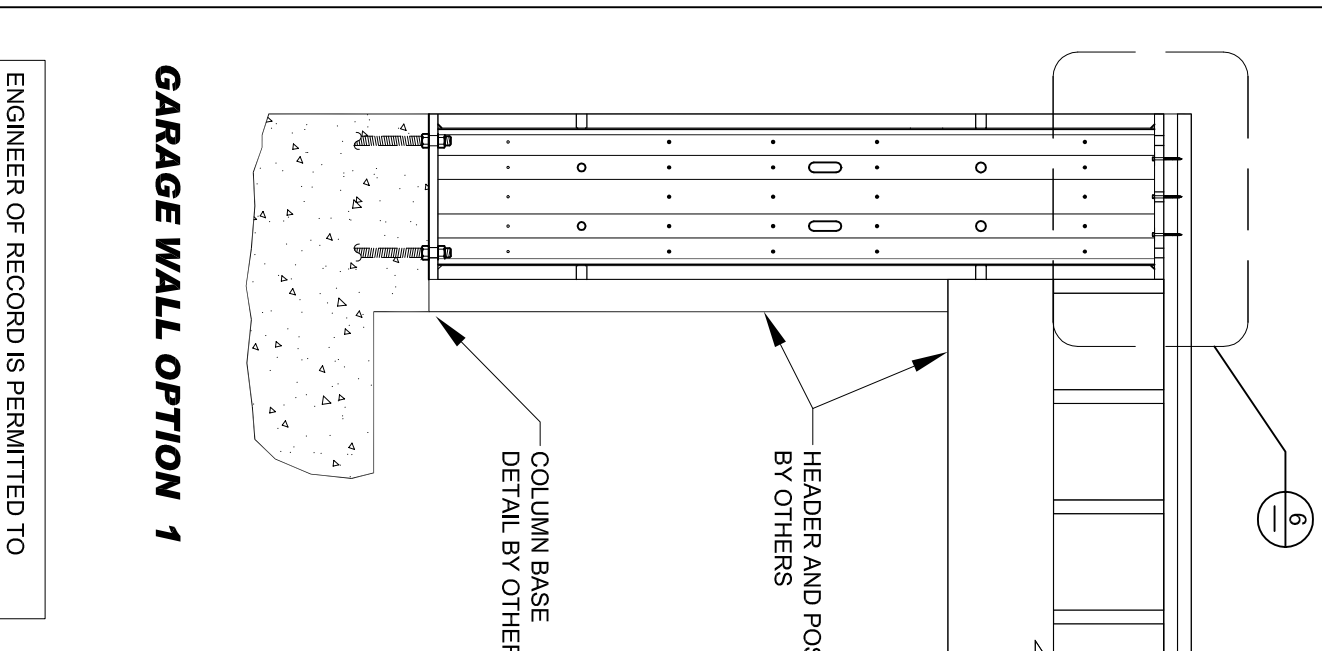
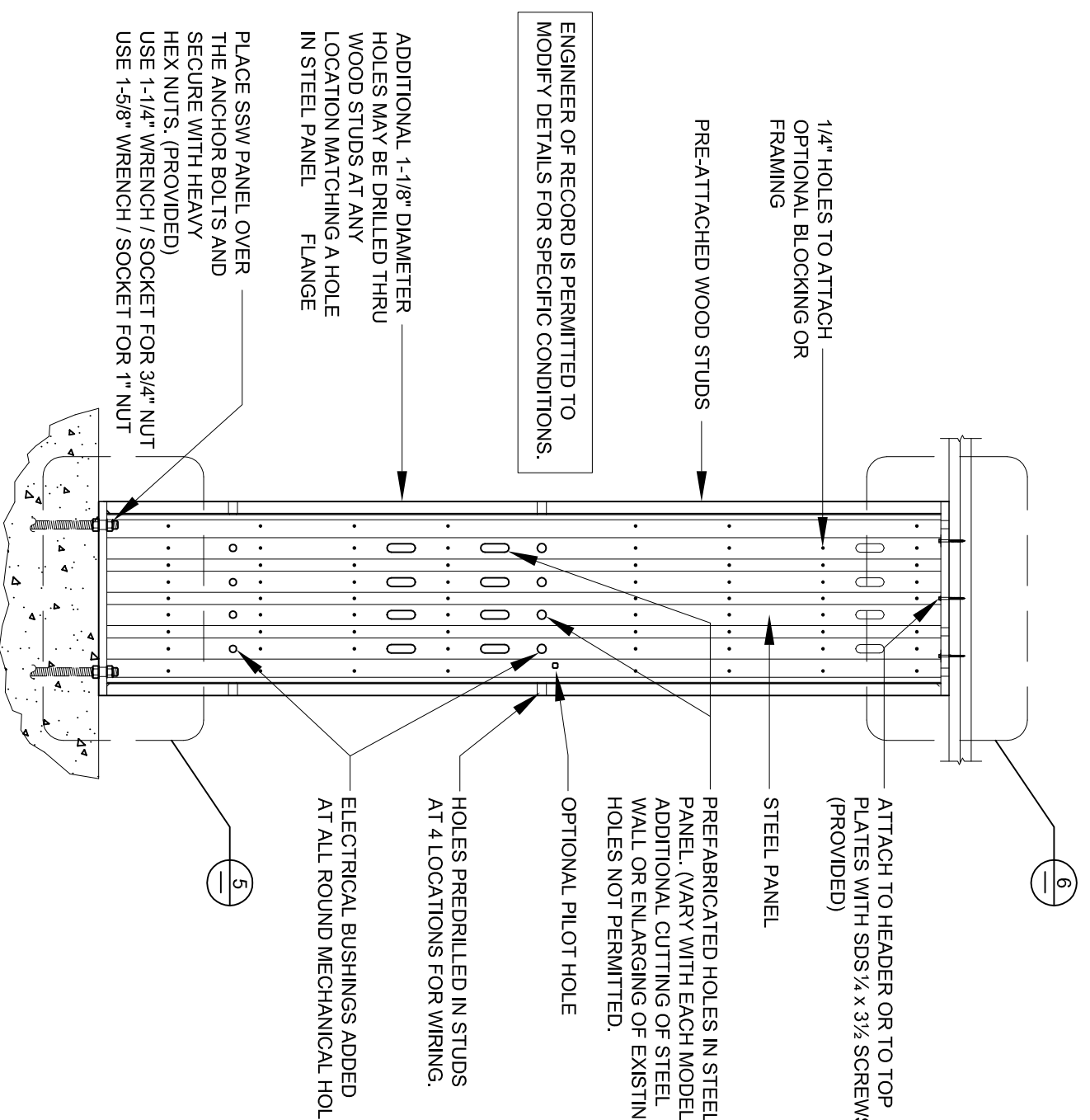

**STEEL STRONG-WALL**

**STEEL STRONG-WALL AT GARAGE**

**STEEL STRONG-WALL HEIGHT ADJUSTMENTS**

**STEEL STRONG-WALL HEIGHT ADJUSTMENTS**

**STEEL STRONG-WALL HEIGHT ADJUSTMENTS**

