

TYP. EXTERIOR FOOTING

1

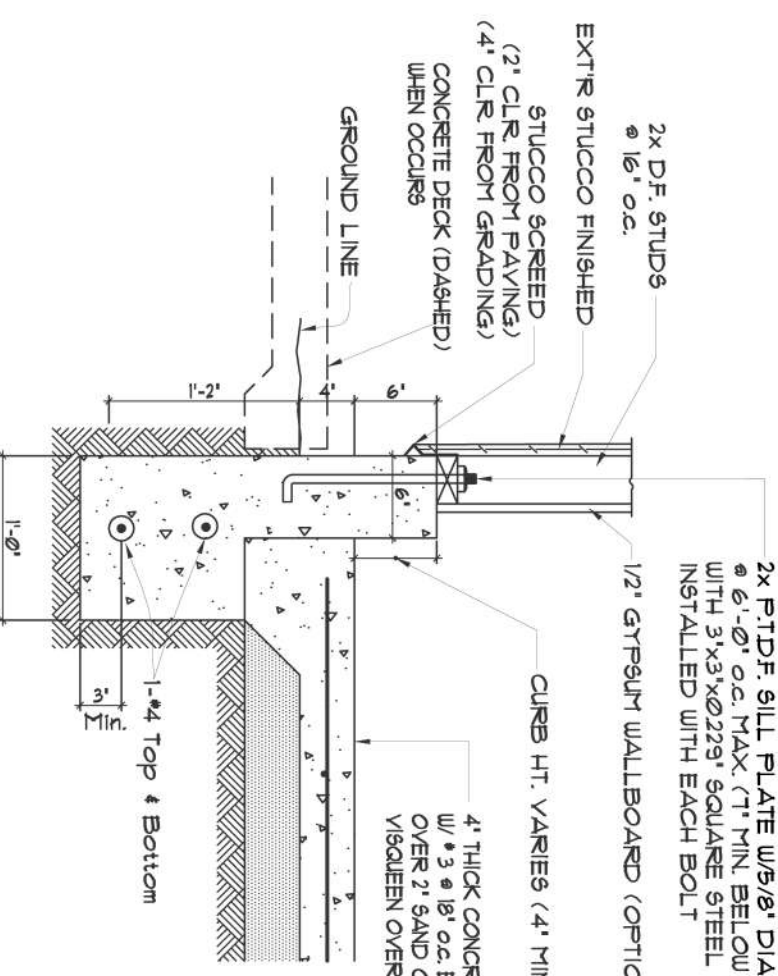

TYP. EXTERIOR GARAGE FOOTING

2

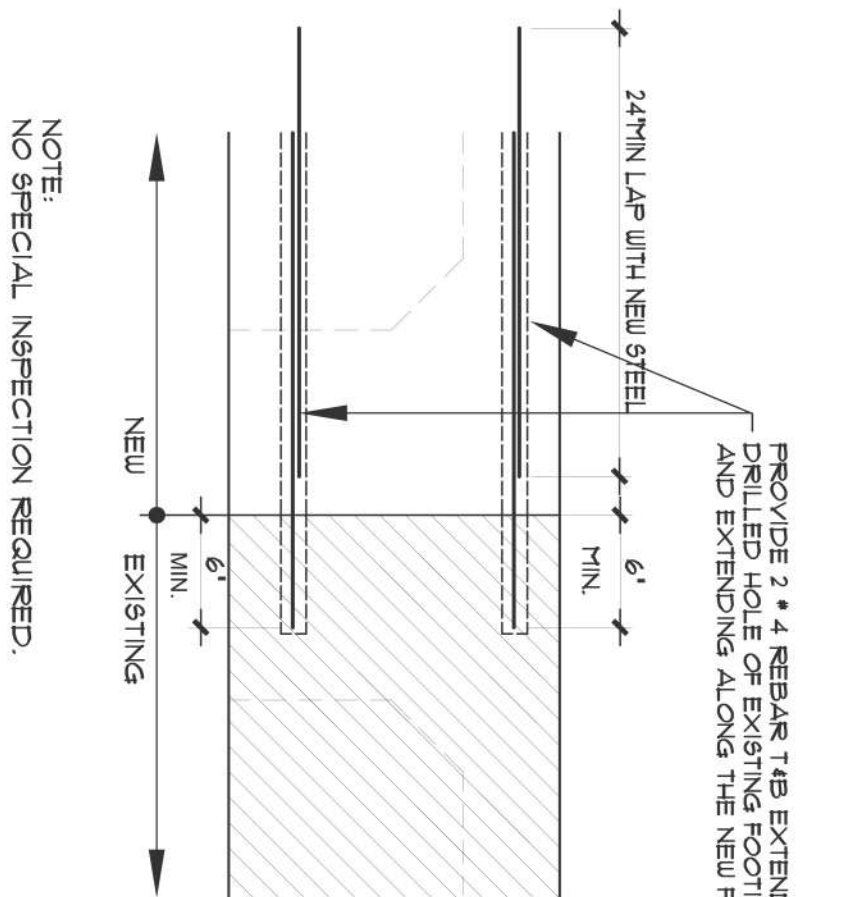

TIE-IN NEW WITH EXISTING

3

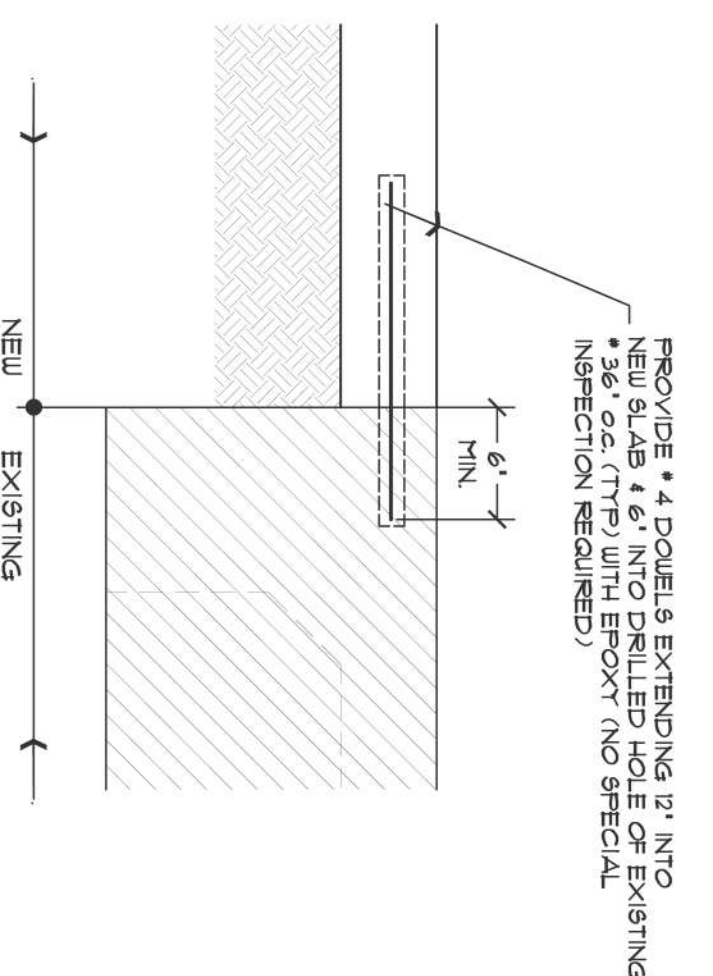

TIE-IN NEW SLAB WITH EXISTING FOOTING

4

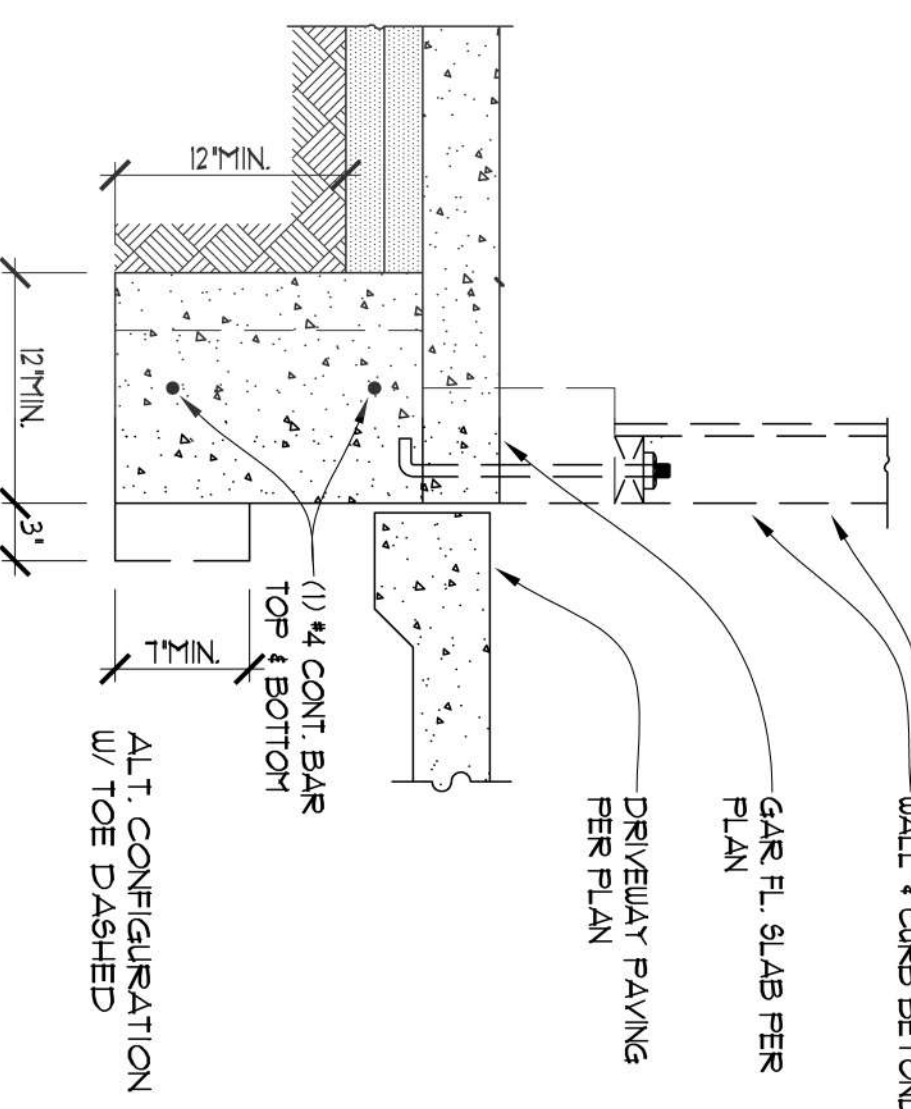

TYP. FOOTING AT GARAGE DOOR

5

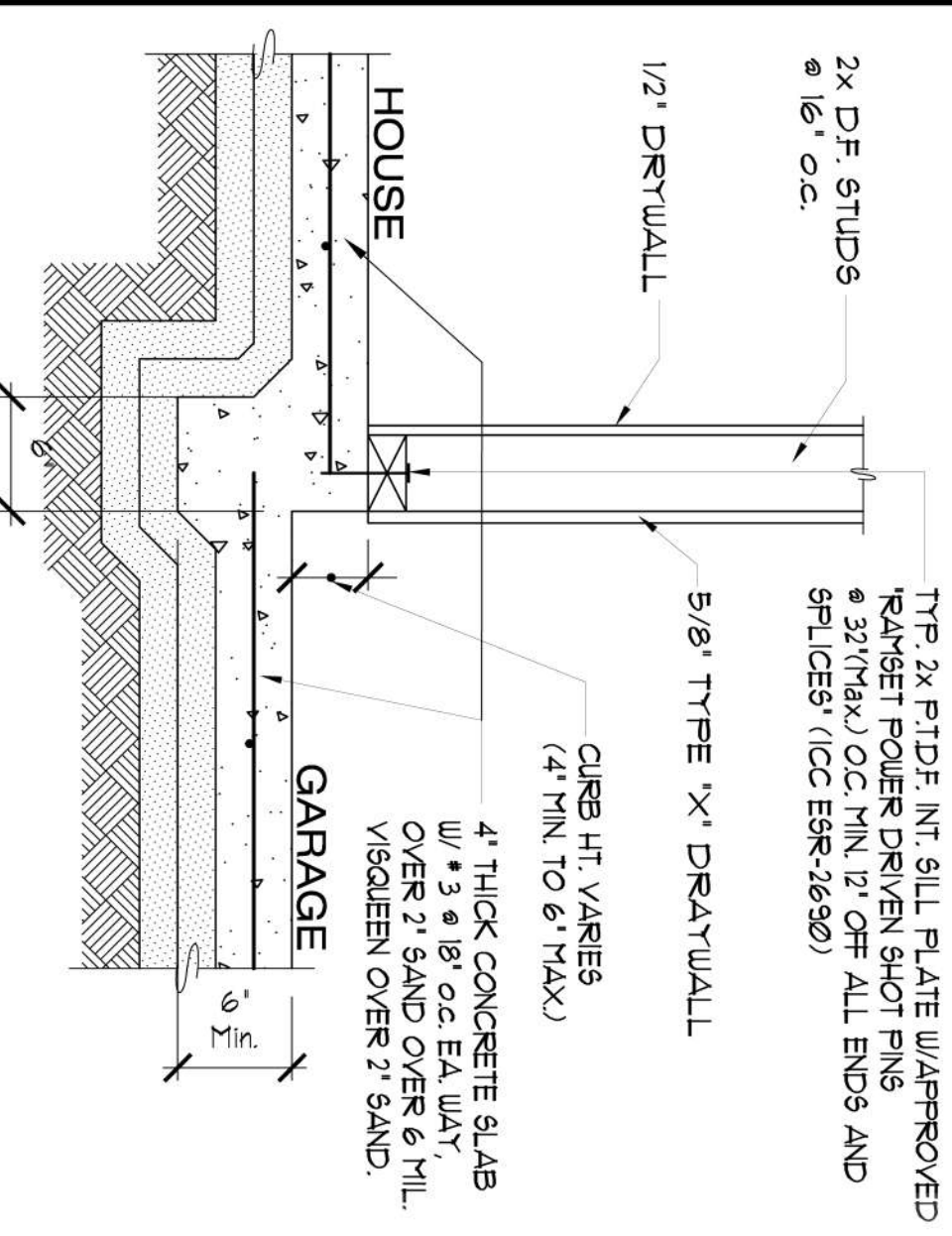

HOUSE-GARAGE SLAB TRANSITION DETAIL

6

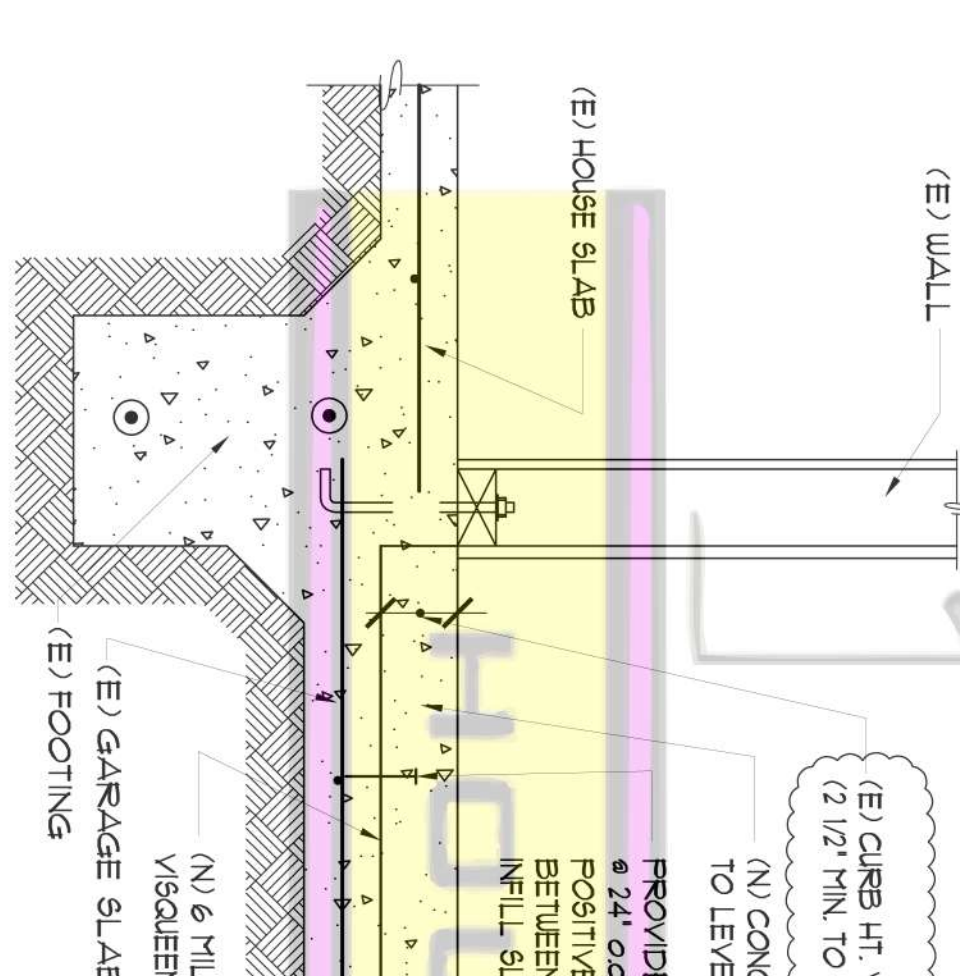

(N) CONCRETE FILL OVER (E) GARAGE SLAB

7

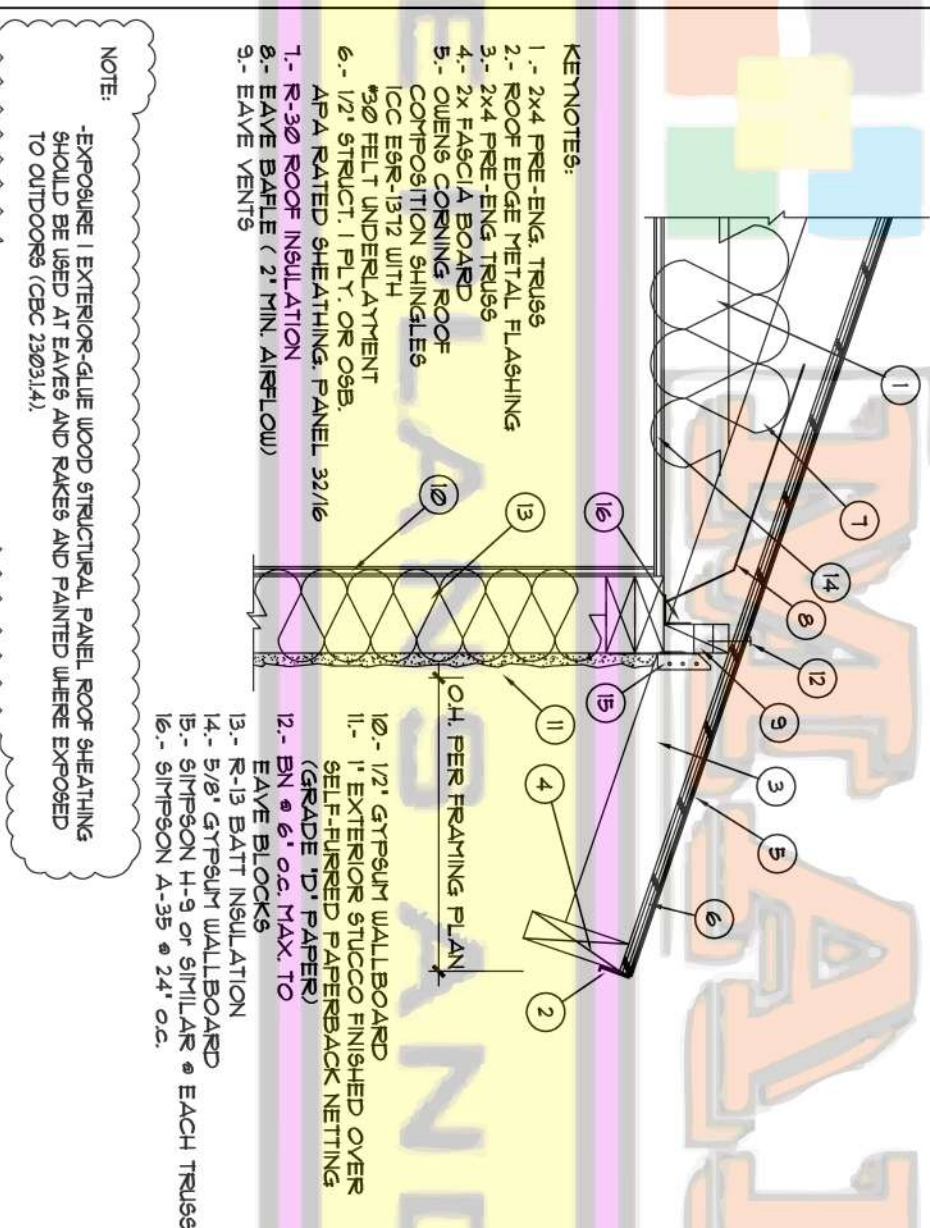

TYP. EAVE DETAIL

8

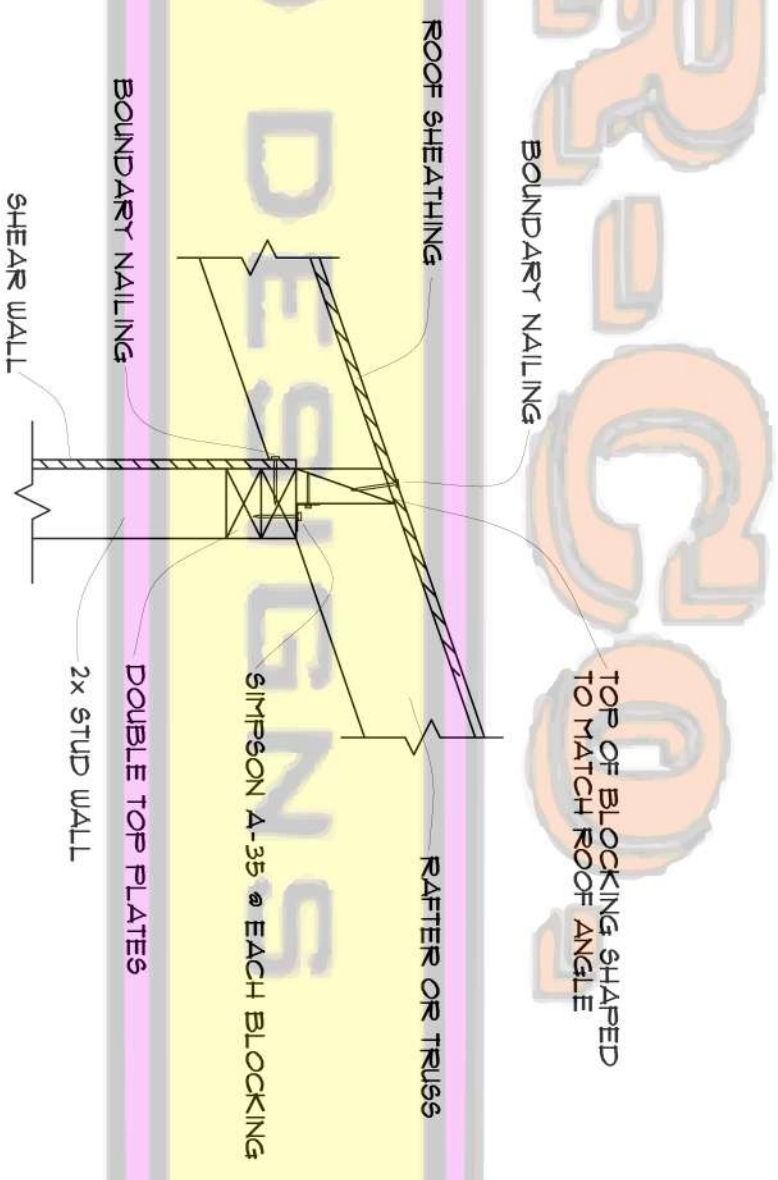

SHEAR WALL CONNECTION AT EAVE

9

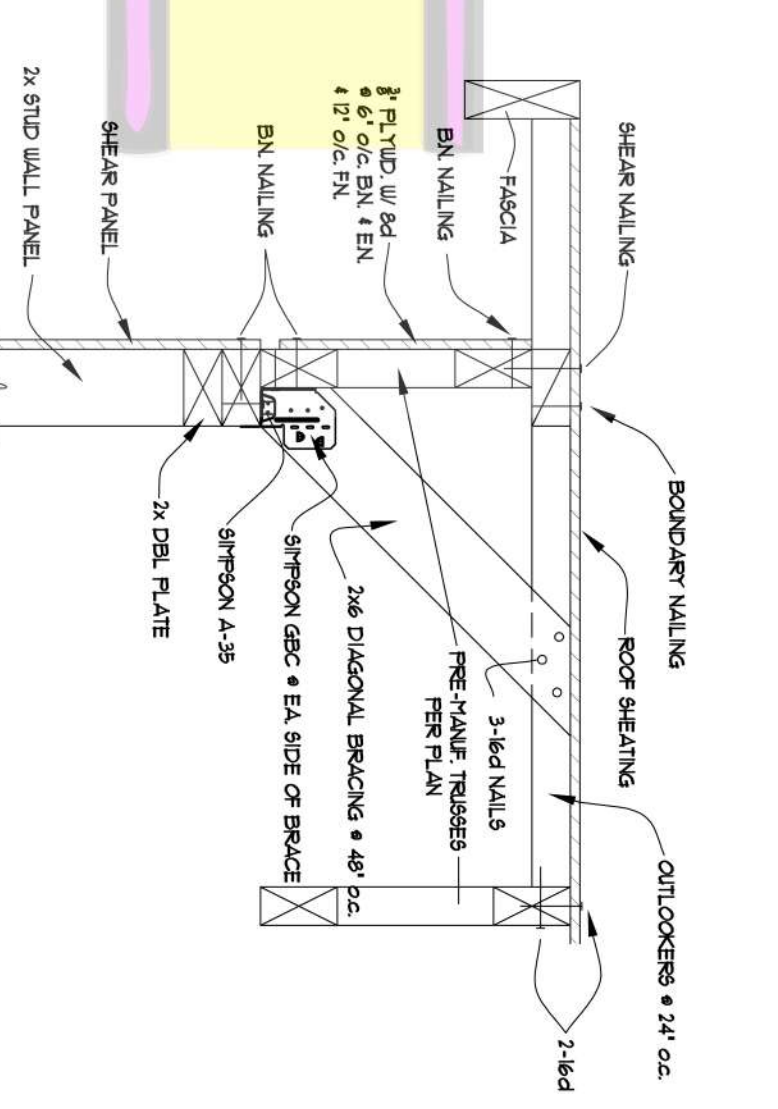

SHEAR WALL CONNECTION AT GABLE END

10

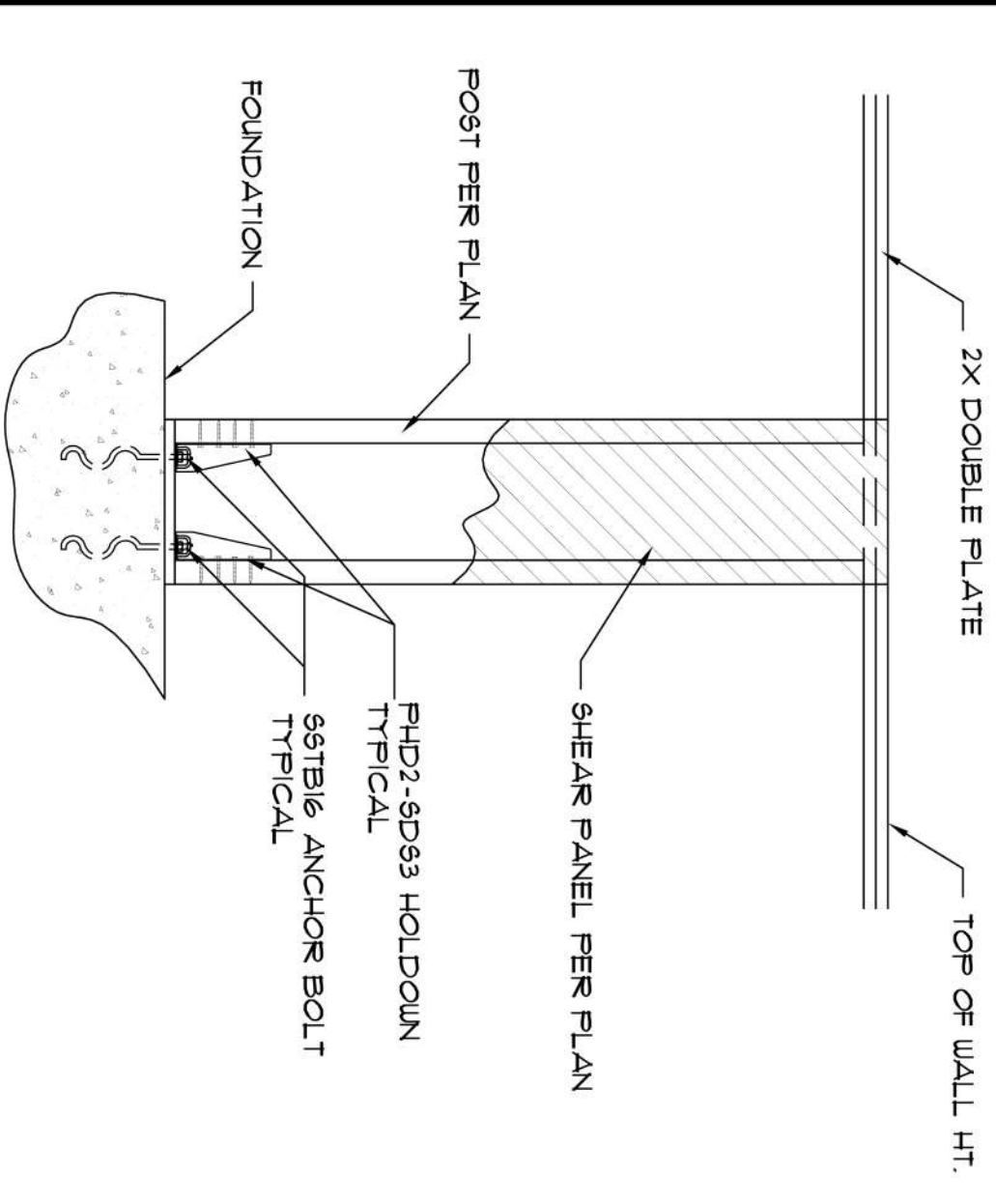

TYP. SHEARWALL DETAIL

11

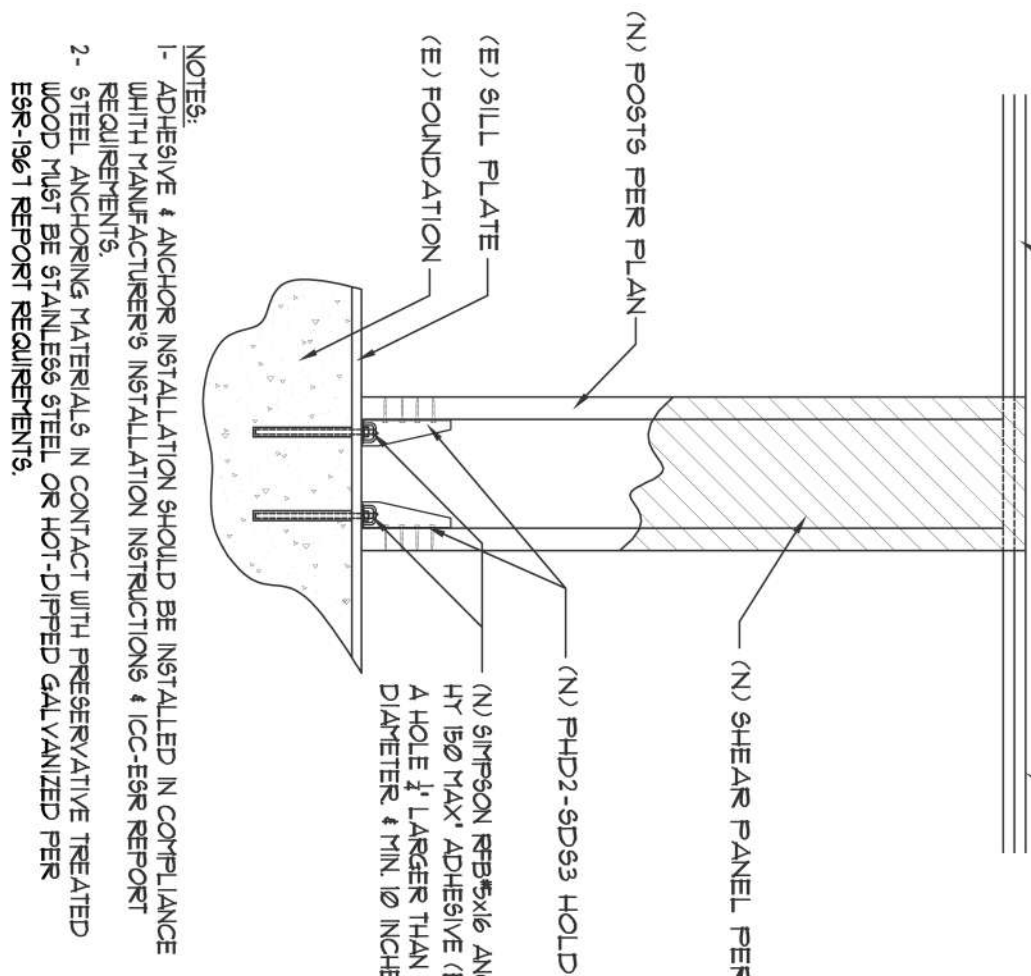

TYP. REINFC. SHEARWALL DETAIL

12

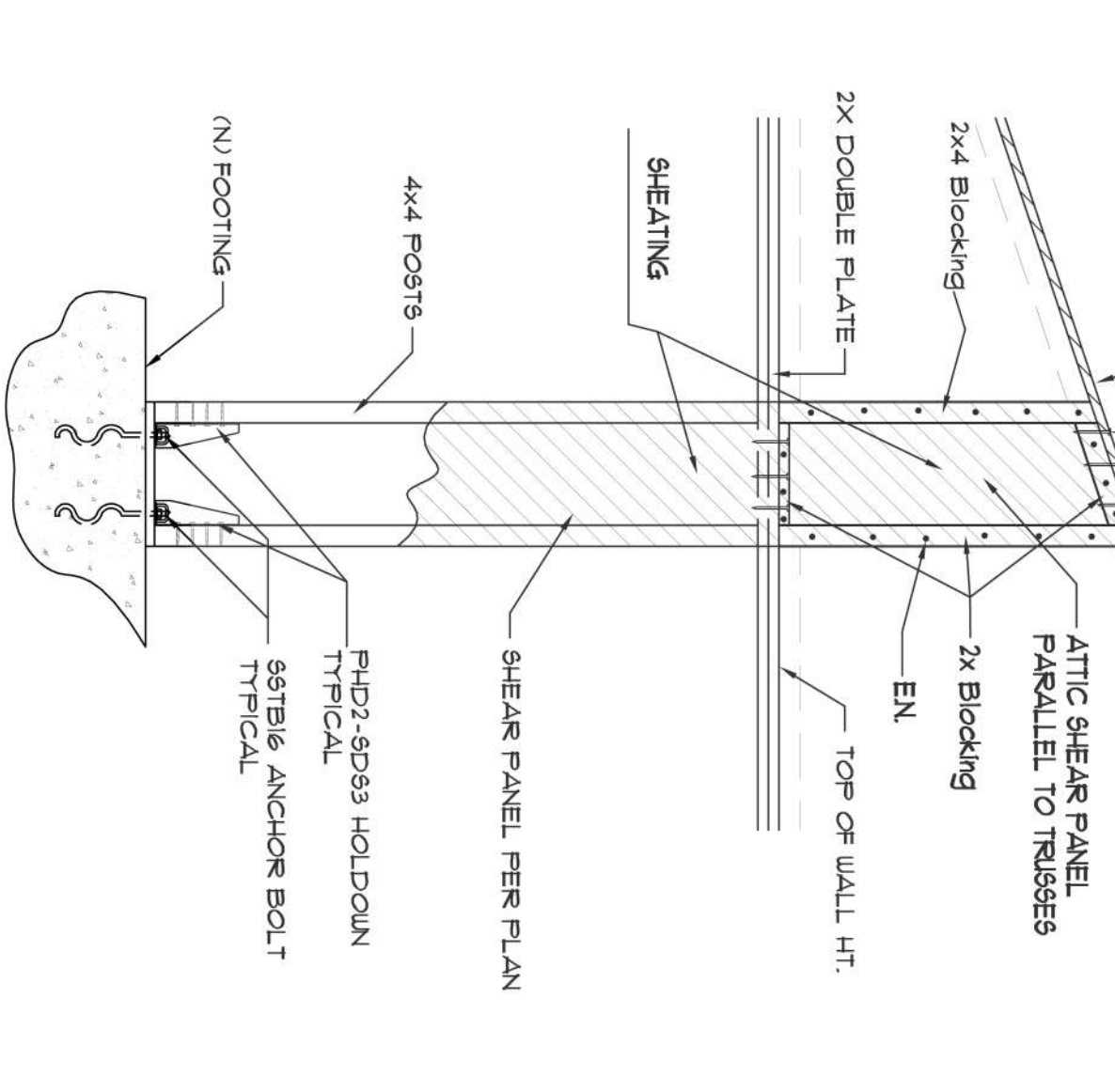

ATTIC SHEARWALL PARALLEL TO TRUSSES

13

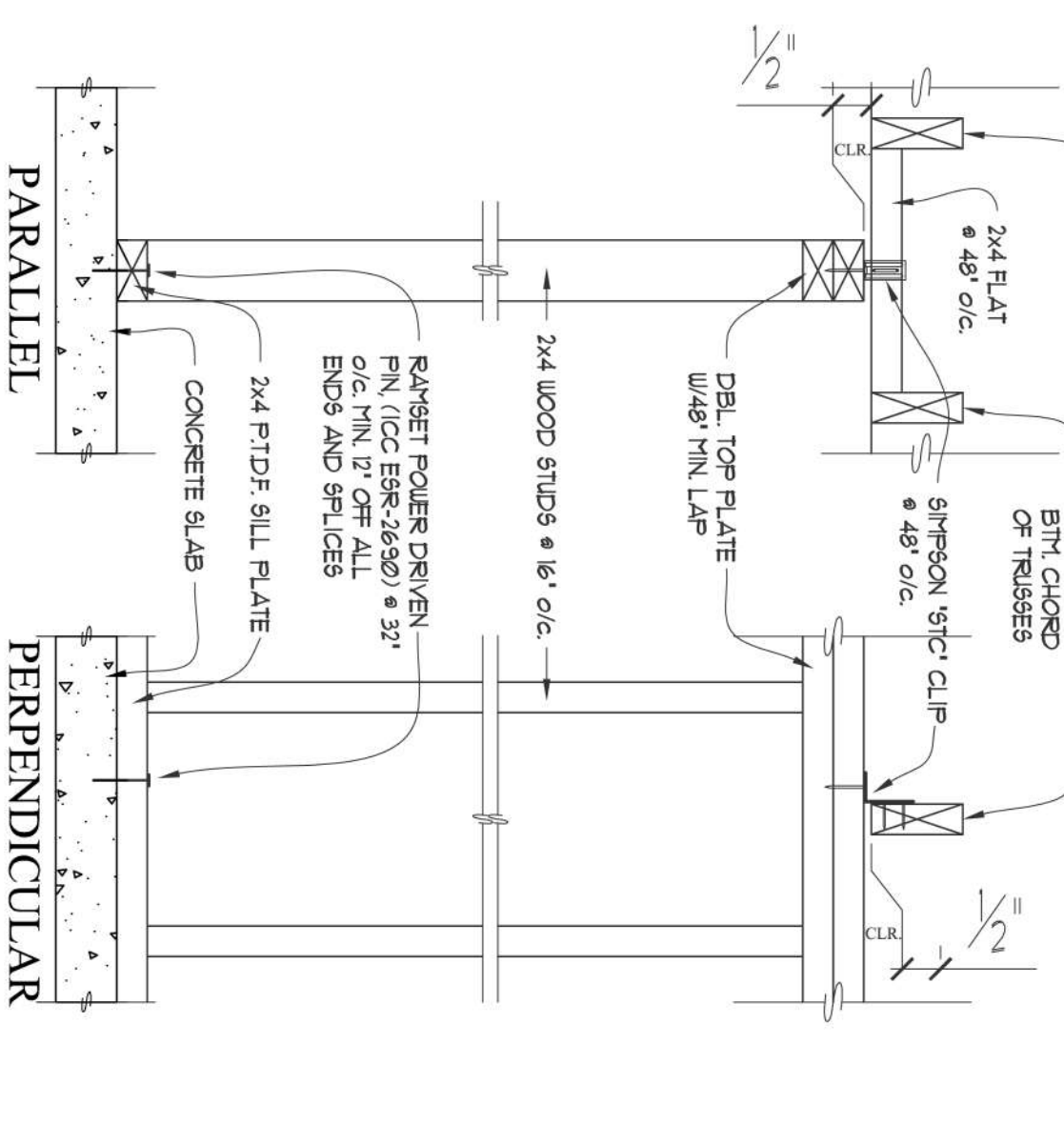

PARTITION WALL DETAIL

14

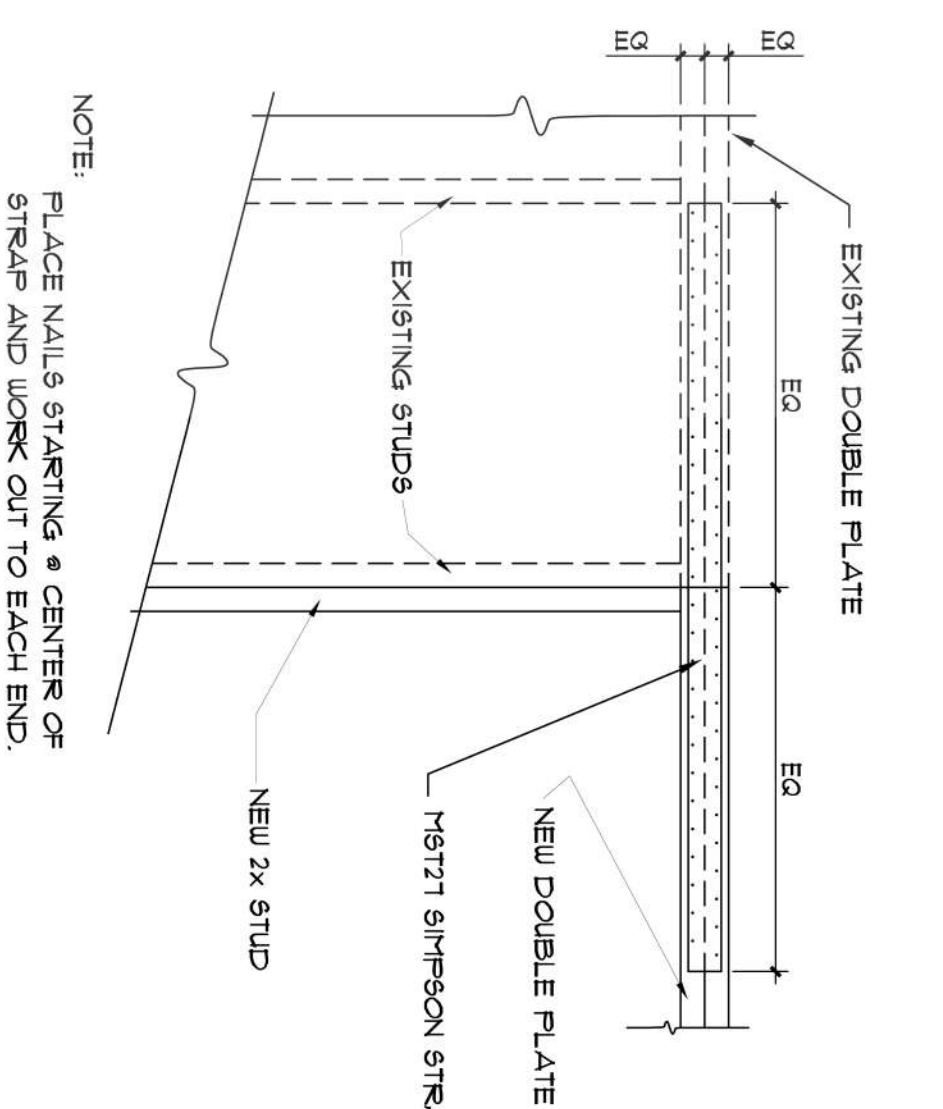

METAL STRAP AT NEW WITH EXISTING

15

**MAR-Co.**  
HOUSE PLANS & DESIGNS  
PLANS-DRAFTING-DESIGNS-3D-BUILDING PERMITS

**MARCO A. LAUREANO**

LICENSE# 16964 760-805-2358  
WWW.MARCHOUSEPLANS.COM 760-941-2678

OWNER'S NAME & ADDRESS:  
**MR. SMITH**  
XXXX WHITEHEAD PL. LA MESA, CA. 91942

PROJECT NAME & ADDRESS:  
**SMITH'S ROOM ADDITION**  
XXXX WHITEHEAD PL. LA MESA, CA. 91942

CONSULTANT:  
SHEET: **D-1**  
SCALE: AS SPECIFIED  
DRAWN & PREPARED BY: MARCO A. LAUREANO

REVISIONS:  
1 12/23/10  
2 01/18/11  
DATE: **11/15/2010**