

CONNECTED TO	DESCRIPTION	SPACING	WALLING SCHEDULE (TABLE 2304.5.1)
1	COMMON BR BAY WALLS	12" ON CENTER	2-8B
2	COMMON BR BAY WALLS	12" ON CENTER	2-8B
3	COMMON BR BAY WALLS	12" ON CENTER	2-8B
4	COMMON BR BAY WALLS	12" ON CENTER	2-8B
5	COMMON BR BAY WALLS	12" ON CENTER	2-8B
6	COMMON BR BAY WALLS	12" ON CENTER	2-8B
7	COMMON BR BAY WALLS	12" ON CENTER	2-8B
8	COMMON BR BAY WALLS	12" ON CENTER	2-8B
9	COMMON BR BAY WALLS	12" ON CENTER	2-8B
10	COMMON BR BAY WALLS	12" ON CENTER	2-8B
11	COMMON BR BAY WALLS	12" ON CENTER	2-8B
12	COMMON BR BAY WALLS	12" ON CENTER	2-8B
13	COMMON BR BAY WALLS	12" ON CENTER	2-8B
14	COMMON BR BAY WALLS	12" ON CENTER	2-8B
15	COMMON BR BAY WALLS	12" ON CENTER	2-8B
16	COMMON BR BAY WALLS	12" ON CENTER	2-8B
17	COMMON BR BAY WALLS	12" ON CENTER	2-8B
18	COMMON BR BAY WALLS	12" ON CENTER	2-8B
19	COMMON BR BAY WALLS	12" ON CENTER	2-8B
20	COMMON BR BAY WALLS	12" ON CENTER	2-8B
21	COMMON BR BAY WALLS	12" ON CENTER	2-8B
22	COMMON BR BAY WALLS	12" ON CENTER	2-8B
23	COMMON BR BAY WALLS	12" ON CENTER	2-8B
24	COMMON BR BAY WALLS	12" ON CENTER	2-8B
25	COMMON BR BAY WALLS	12" ON CENTER	2-8B
26	COMMON BR BAY WALLS	12" ON CENTER	2-8B
27	COMMON BR BAY WALLS	12" ON CENTER	2-8B
28	COMMON BR BAY WALLS	12" ON CENTER	2-8B
29	COMMON BR BAY WALLS	12" ON CENTER	2-8B
30	COMMON BR BAY WALLS	12" ON CENTER	2-8B
31	COMMON BR BAY WALLS	12" ON CENTER	2-8B
32	COMMON BR BAY WALLS	12" ON CENTER	2-8B
33	COMMON BR BAY WALLS	12" ON CENTER	2-8B
34	COMMON BR BAY WALLS	12" ON CENTER	2-8B
35	COMMON BR BAY WALLS	12" ON CENTER	2-8B
36	COMMON BR BAY WALLS	12" ON CENTER	2-8B
37	COMMON BR BAY WALLS	12" ON CENTER	2-8B
38	COMMON BR BAY WALLS	12" ON CENTER	2-8B
39	COMMON BR BAY WALLS	12" ON CENTER	2-8B
40	COMMON BR BAY WALLS	12" ON CENTER	2-8B
41	COMMON BR BAY WALLS	12" ON CENTER	2-8B
42	COMMON BR BAY WALLS	12" ON CENTER	2-8B
43	COMMON BR BAY WALLS	12" ON CENTER	2-8B
44	COMMON BR BAY WALLS	12" ON CENTER	2-8B
45	COMMON BR BAY WALLS	12" ON CENTER	2-8B
46	COMMON BR BAY WALLS	12" ON CENTER	2-8B
47	COMMON BR BAY WALLS	12" ON CENTER	2-8B
48	COMMON BR BAY WALLS	12" ON CENTER	2-8B
49	COMMON BR BAY WALLS	12" ON CENTER	2-8B
50	COMMON BR BAY WALLS	12" ON CENTER	2-8B

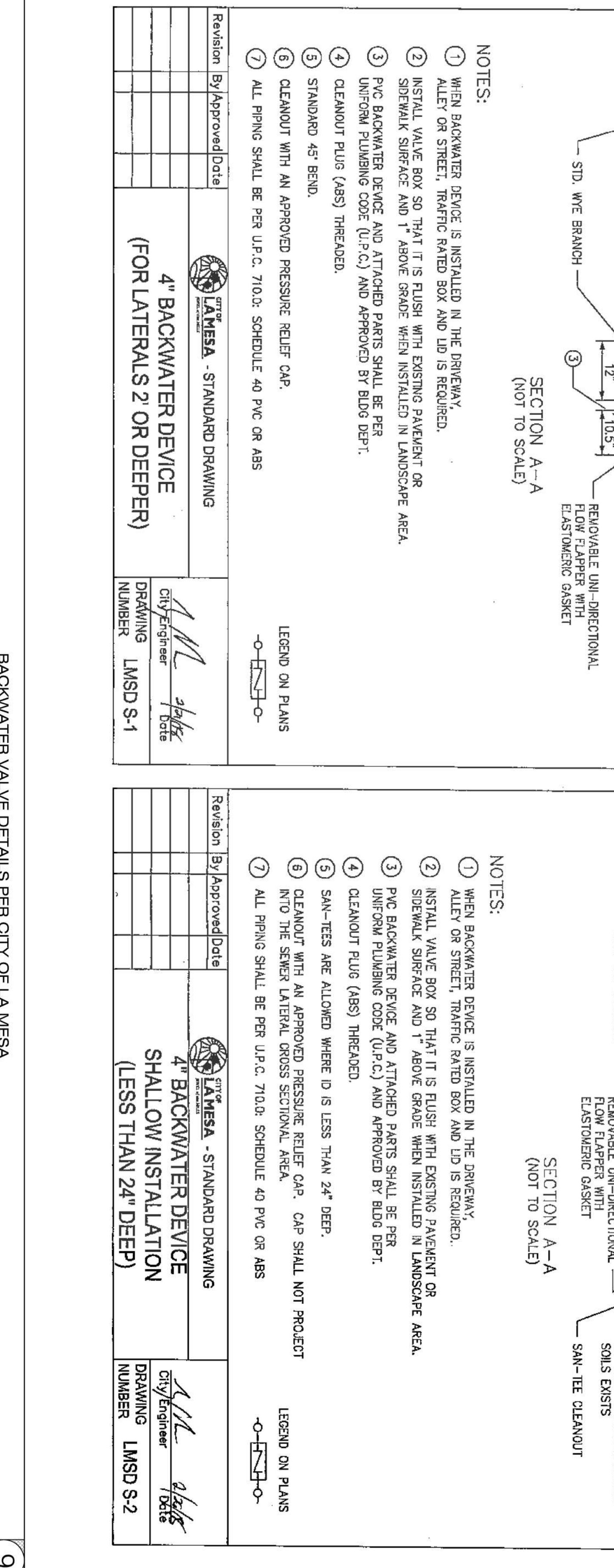
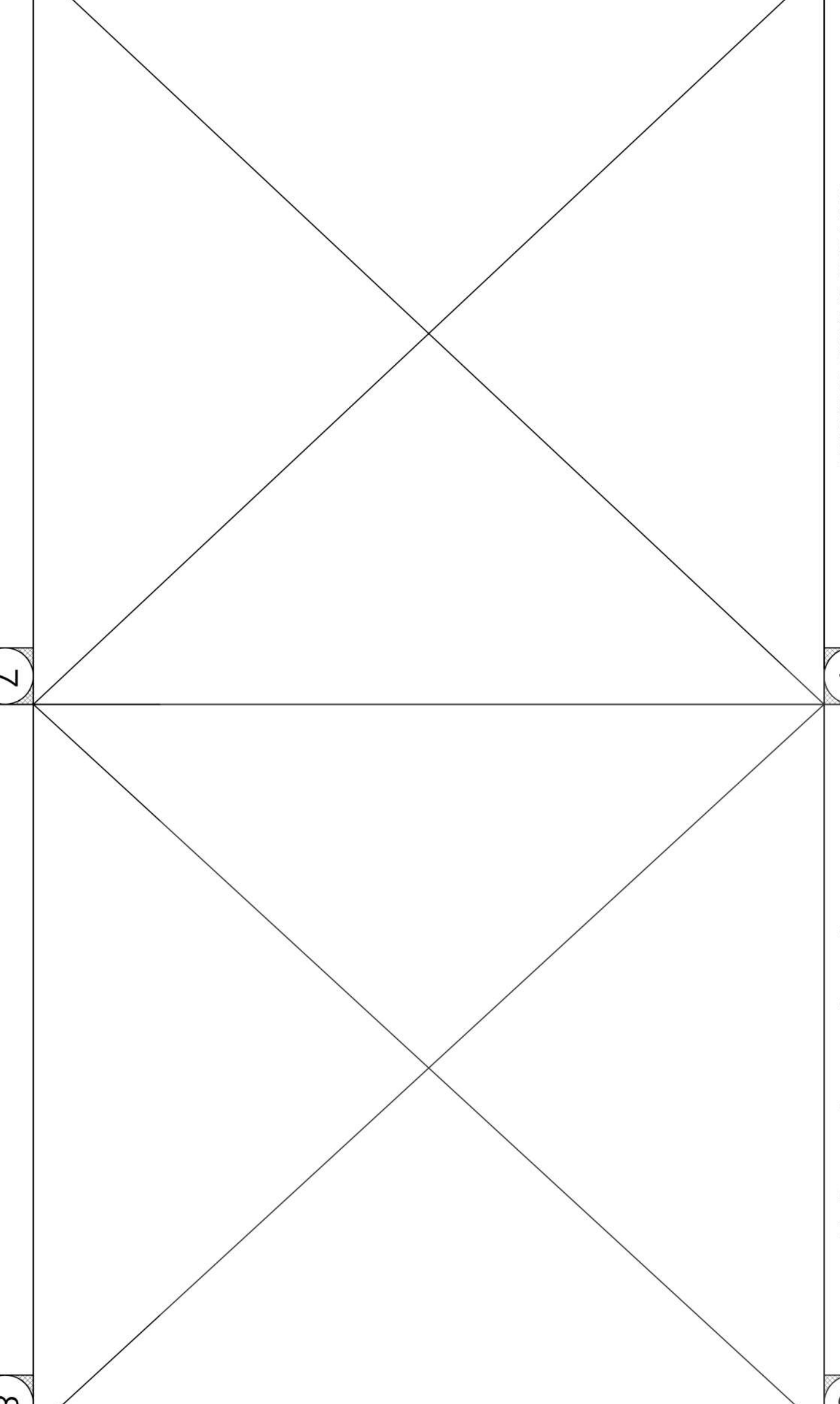
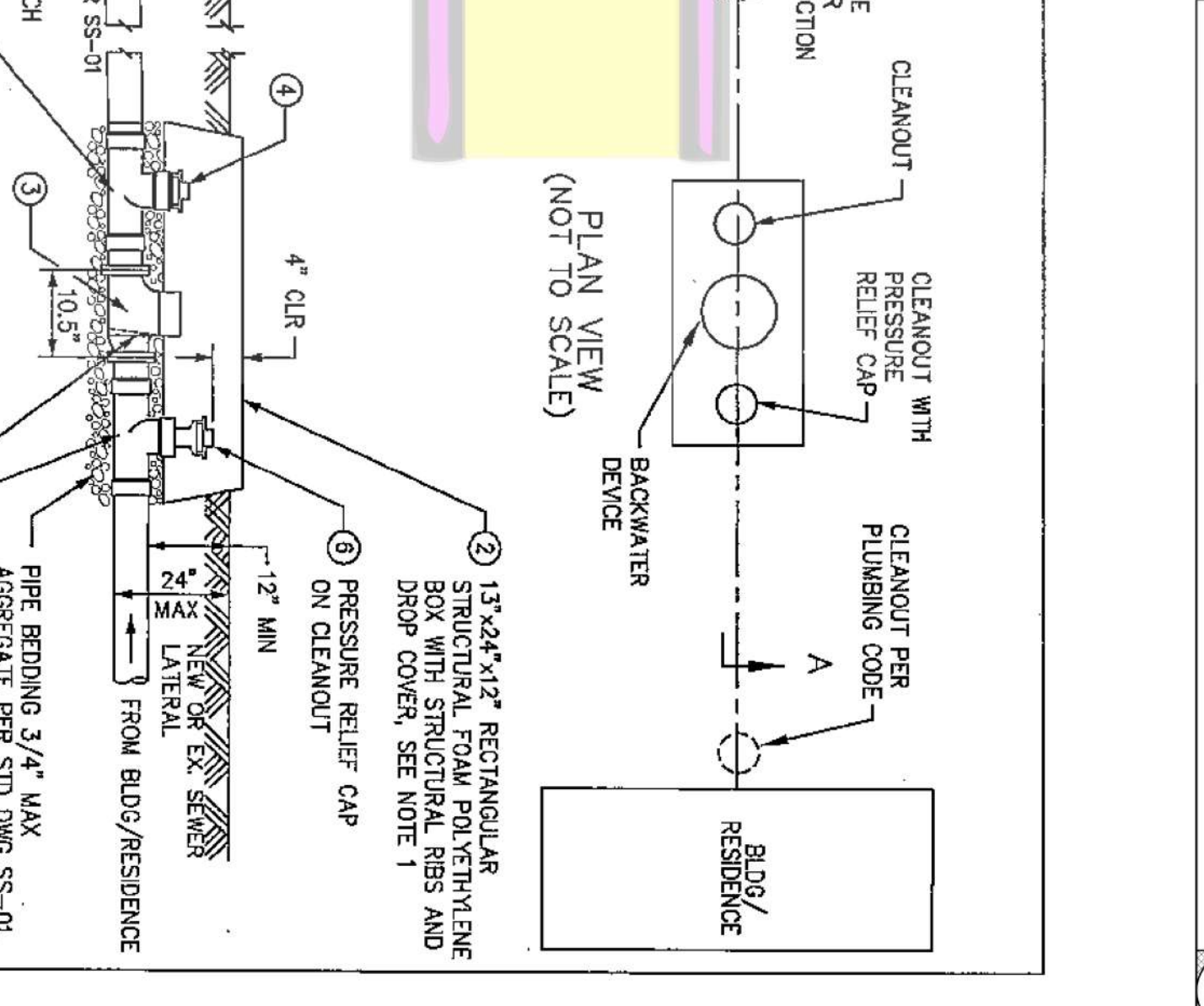
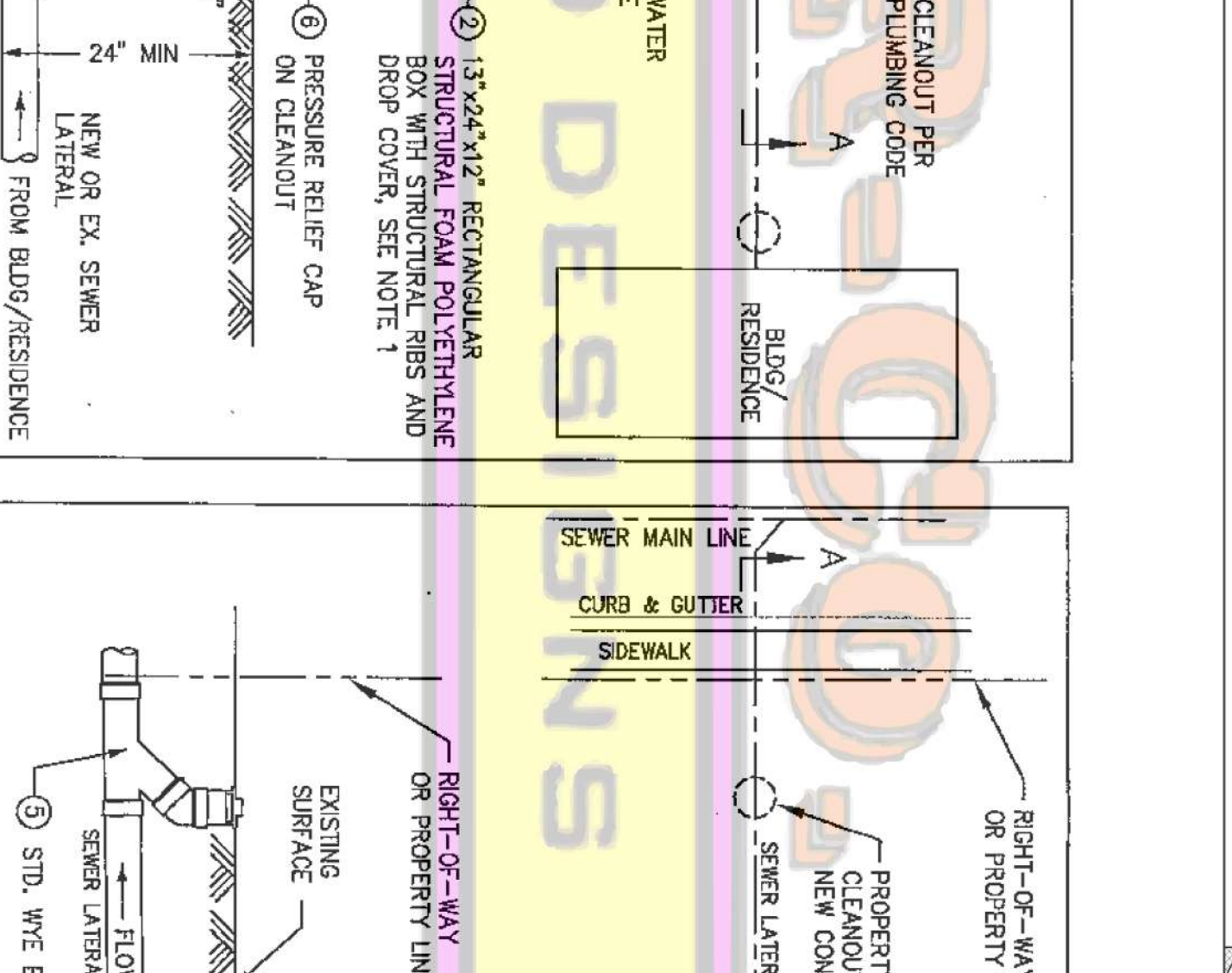
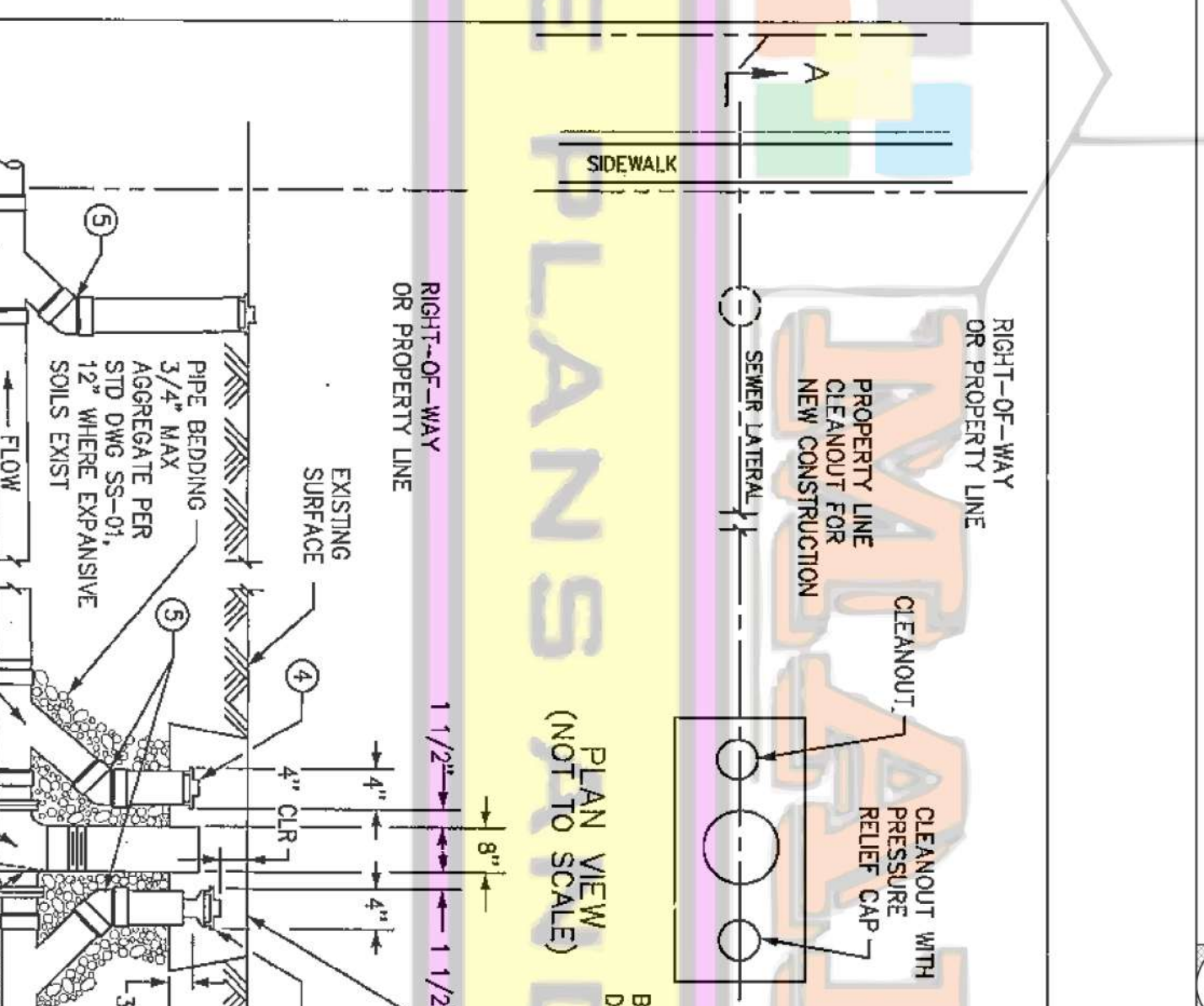
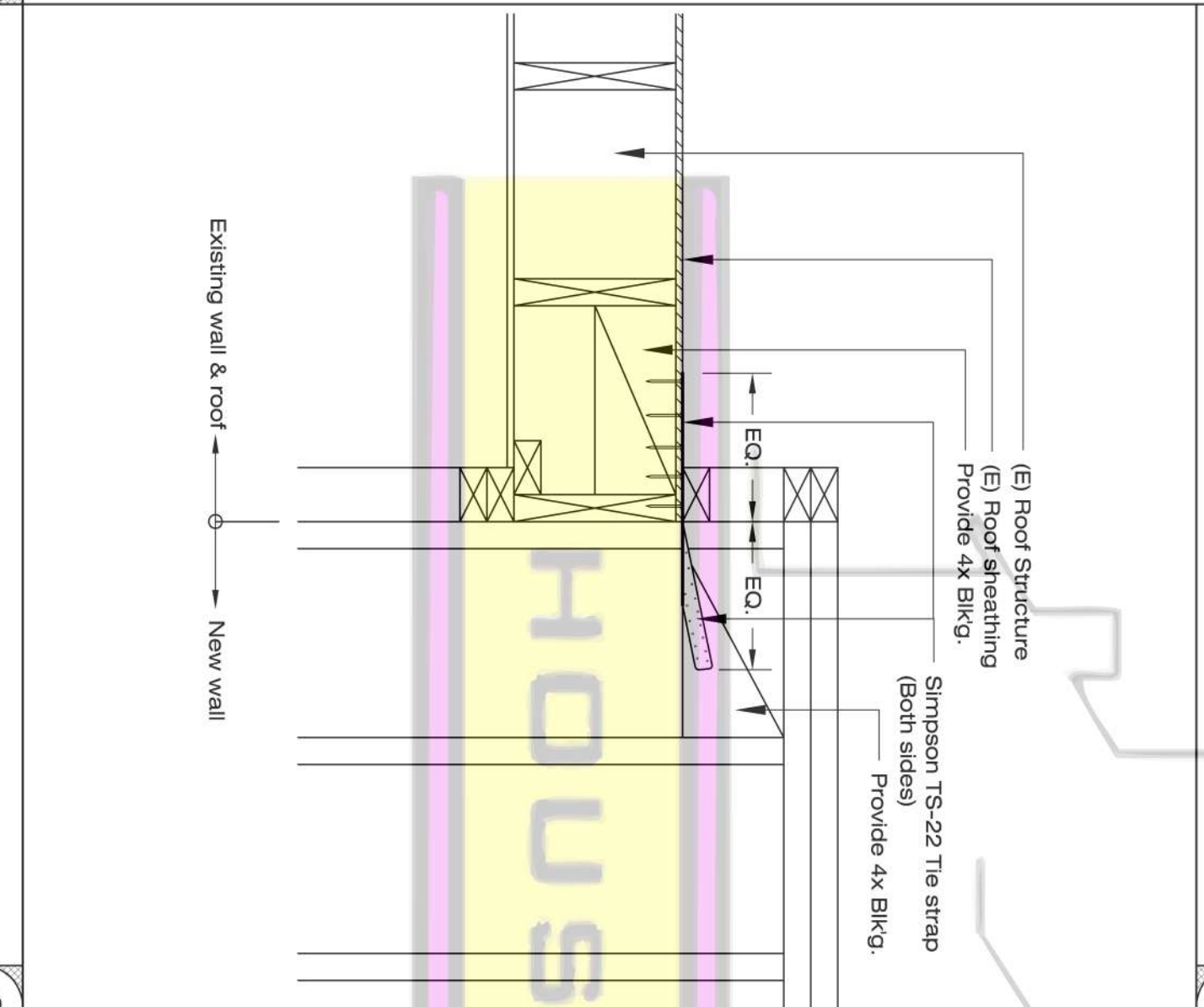
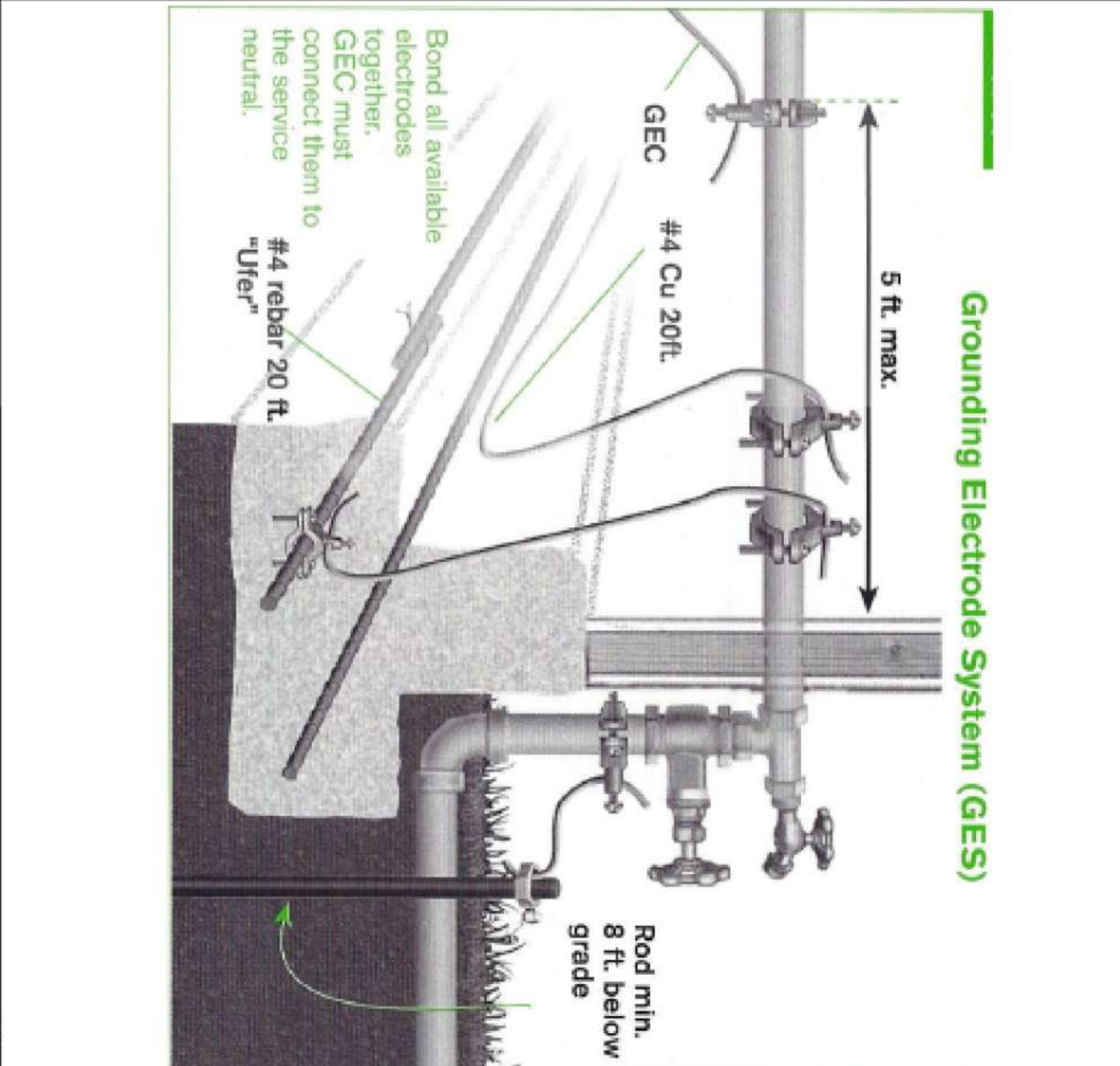
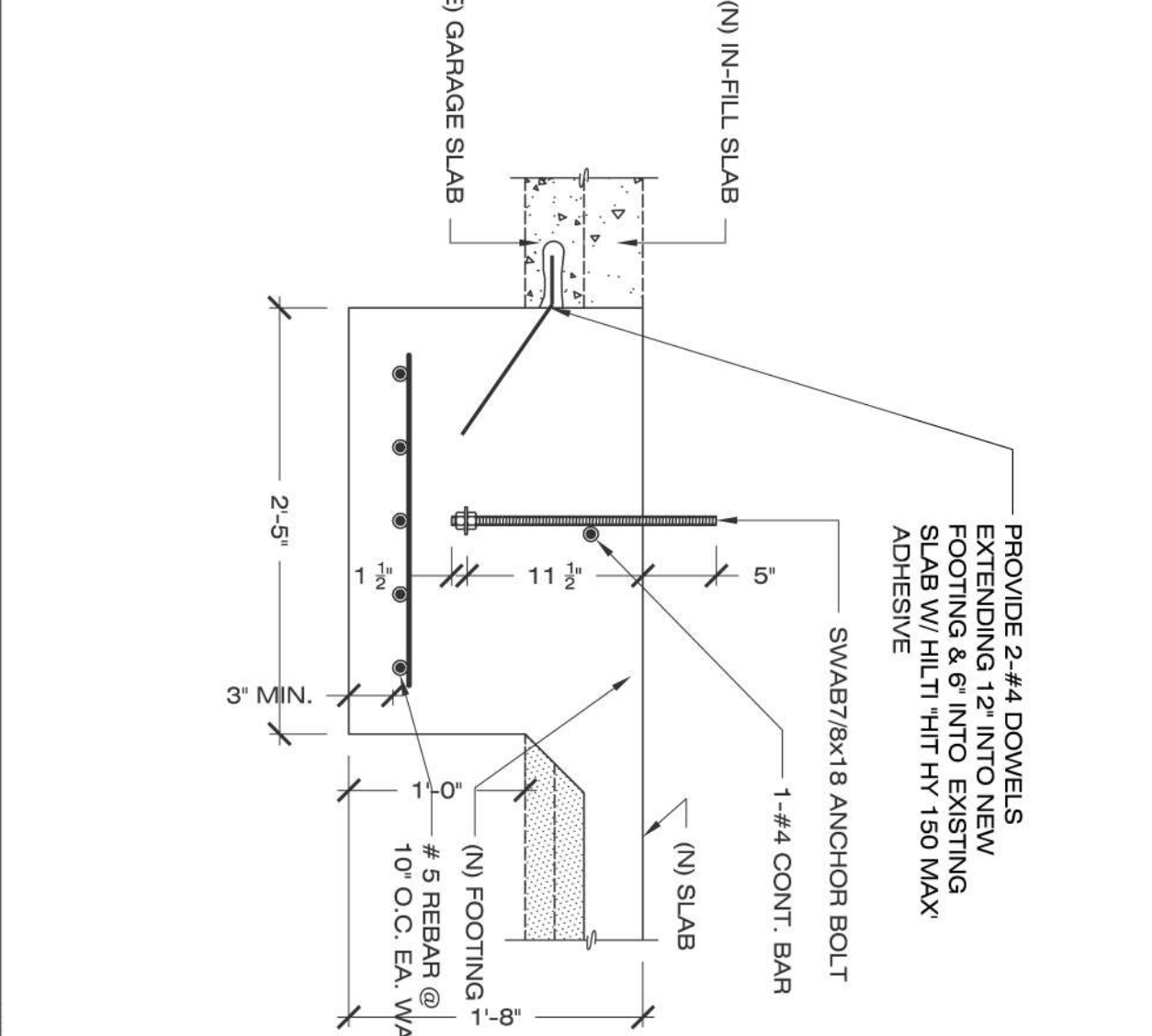
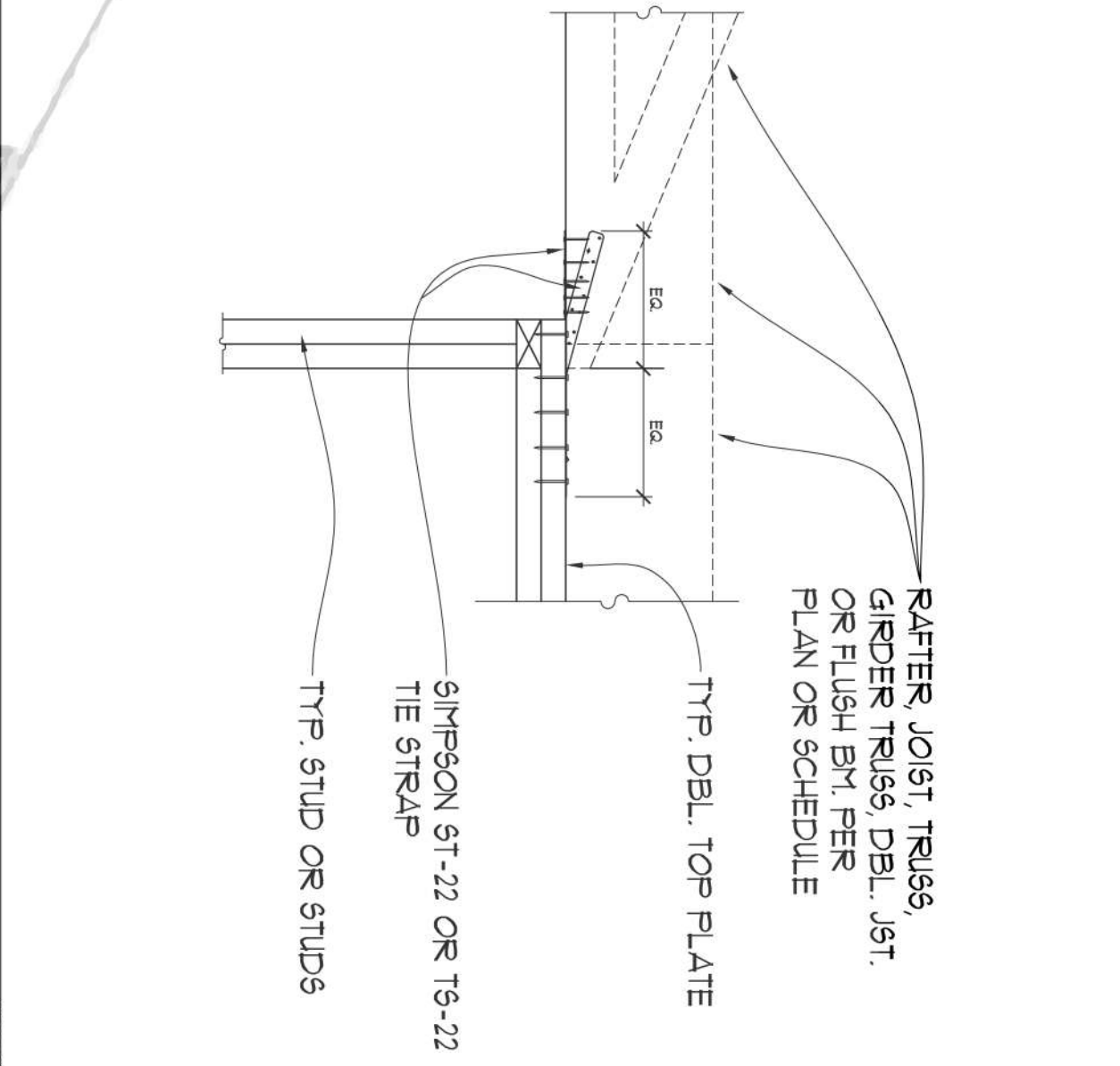
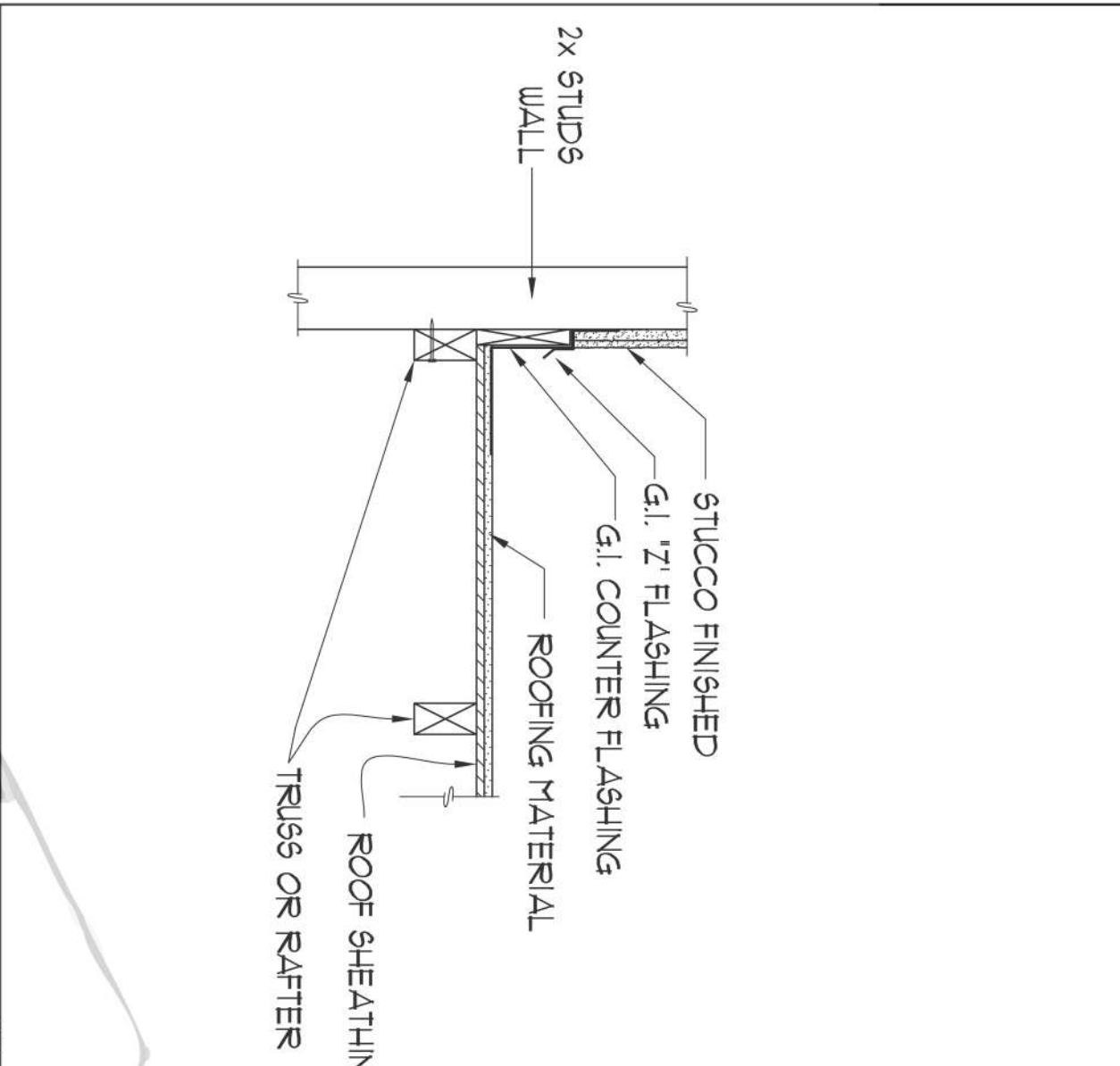
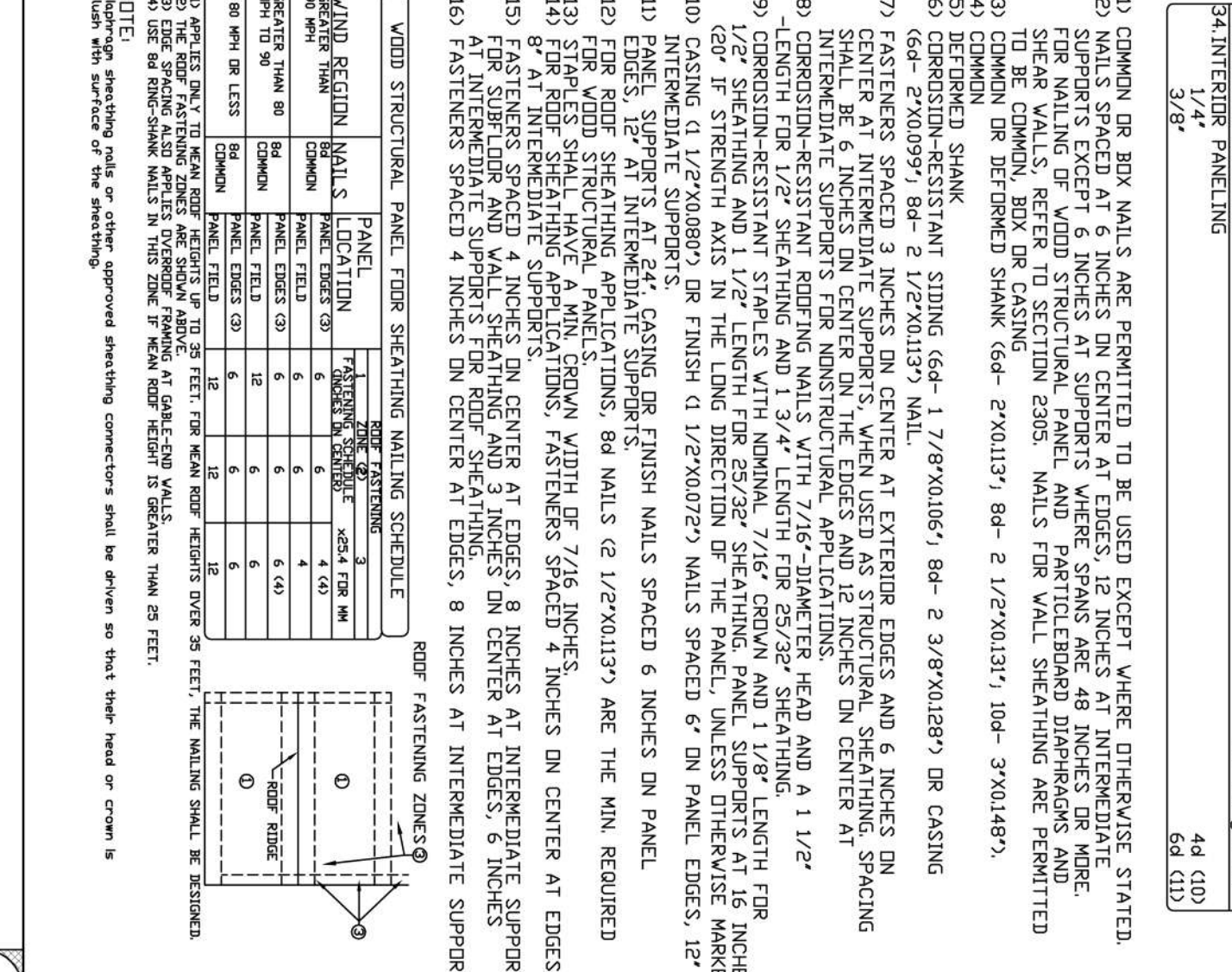

**REVISIONS:**

NO.	DATE	DESCRIPTION
1	11/15/2010	AS SPECIFIED DRAWN & PREPARED BY MARCO A. LAUREANO

**SCALE:** 1/8" = 1'-0"

**SHEET:** D-2

**OF:** 9

**MAR-Co.**  
HOUSE PLANS & DESIGNS  
PLANS-DRAFTING-DESIGNS-3D-BUILDING PERMITS  
MARCO A. LAUREANO

**MAR-Co.**  
HOUSE PLANS & DESIGNS  
PLANOS-DIBUJO-DISEÑOS-3D-PERMISSOS  
MARCO A. LAUREANO

LICENSE: 16964 760-805-2358  
 WWW.MARCOHOUSEPLANS.COM 760-941-2678  
 LICENSE: 16964 760-805-2358  
 WWW.MARCOHOUSEPLANS.COM 760-941-2678

OWNER'S NAME & ADDRESS:  
 MR. SMITH  
 XXXX WHITEHEAD PL. LA MESA, CA. 91942

PROJECT NAME & ADDRESS:  
 SMITH'S ROOM ADDITION  
 XXXX WHITEHEAD PL. LA MESA, CA. 91942

CONSULTANT:

REVISIONS:

NO.	DATE	DESCRIPTION
1	11/15/2010	AS SPECIFIED DRAWN & PREPARED BY MARCO A. LAUREANO

**SCALE:** 1/8" = 1'-0"

**SHEET:** D-2

**OF:** 9