

TIE-IN (N) PAD FOOTING WITH (E) FOOTING

1

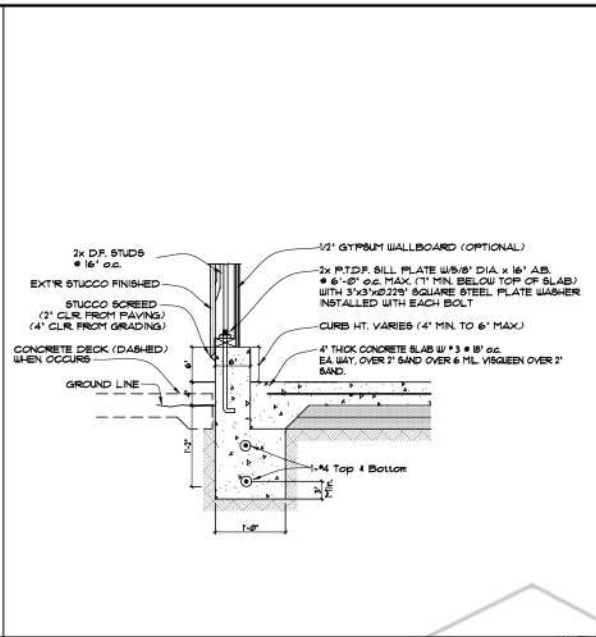

TYP PERIMETER GARAGE FOOTING

2

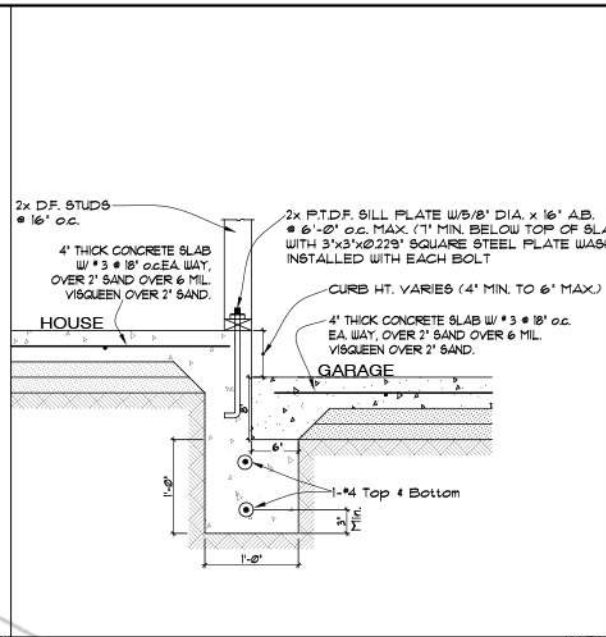

FOOTING @ HOUSE-GARAGE TRANSITION

3

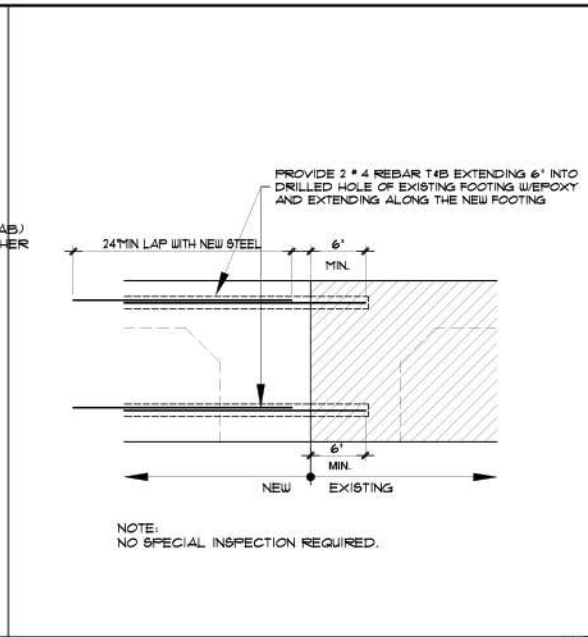

TIE-IN NEW WITH EXISTING

4

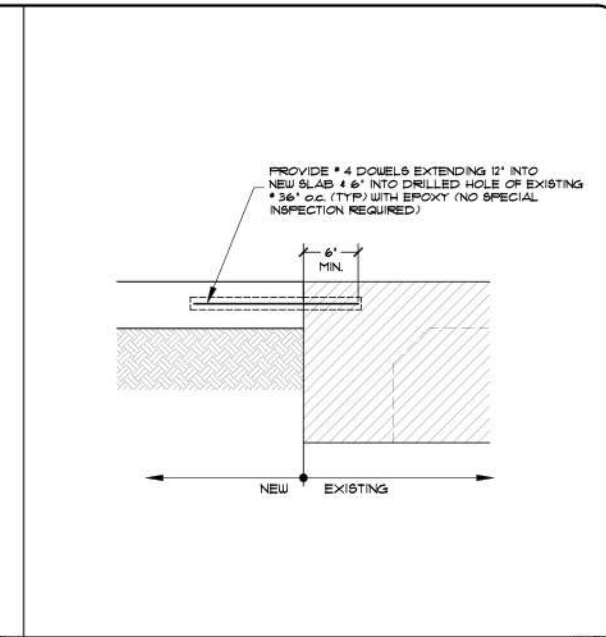

TIE-IN NEW SLAB WITH EXISTING FOOTING

5

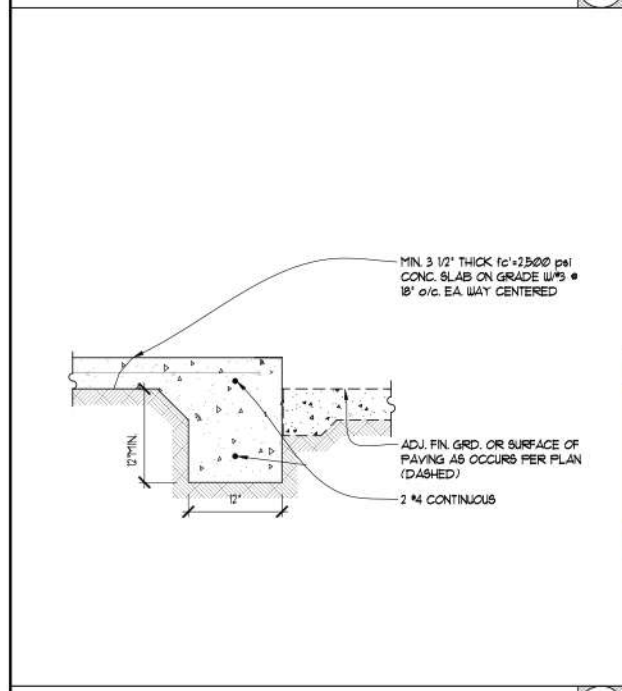

PERIMETER FOOTING @ PORCH OR COVERED PATIO

6

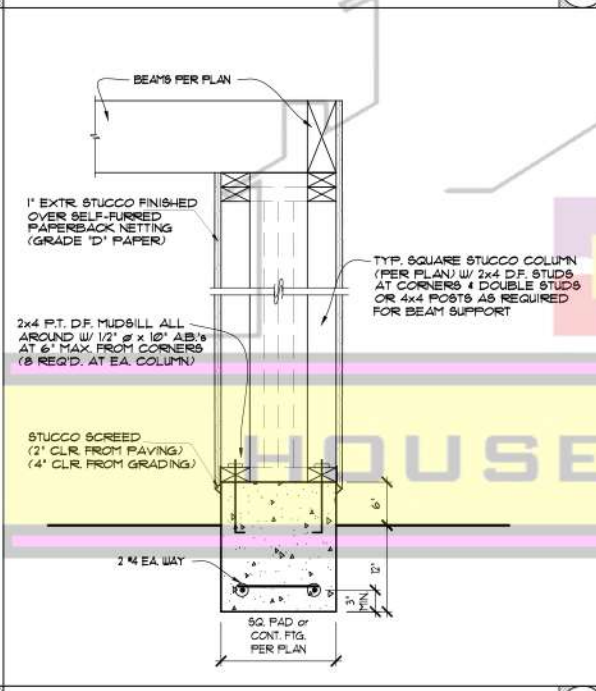

COLUMN DETAIL

7

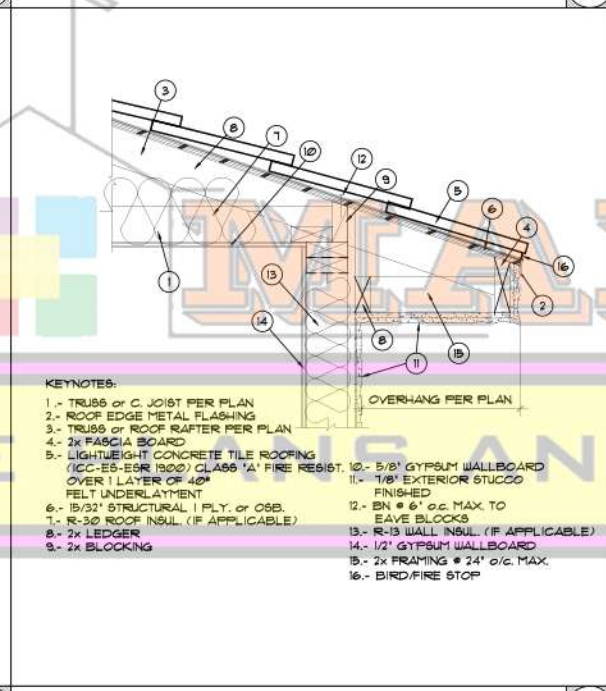

TYP. ENHANCED EAVE DETAIL

8

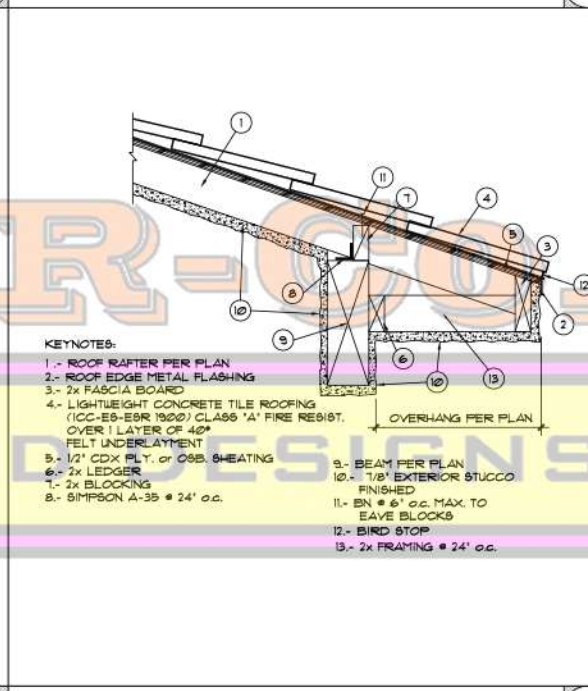

TYP. ENHANCED EAVE DETAIL W/STUCCOED BEAM & CEILING

9

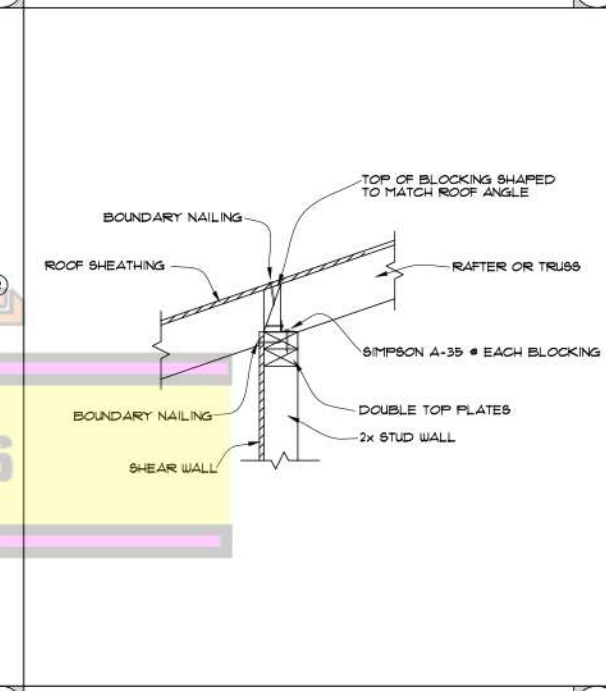

SHEAR TRANSFER AT EAVE DETAIL

10

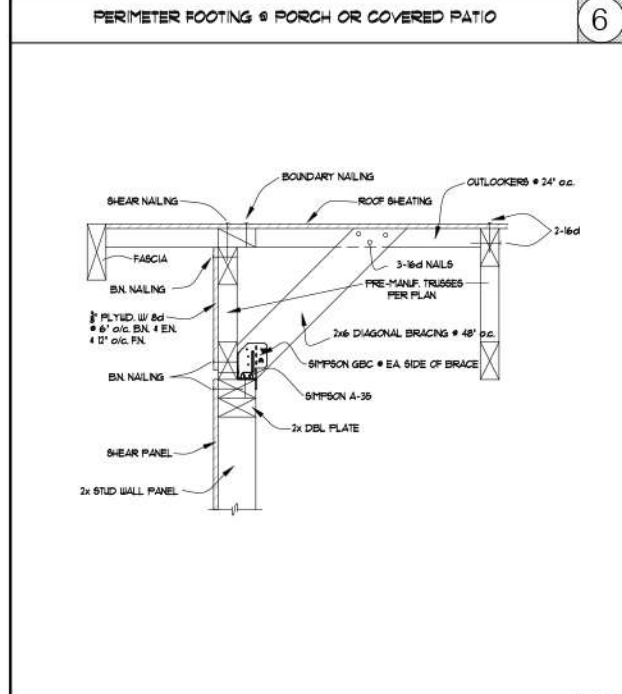

GABLE END TRUSS & SHEARWALL CONNECTION DETAIL

11

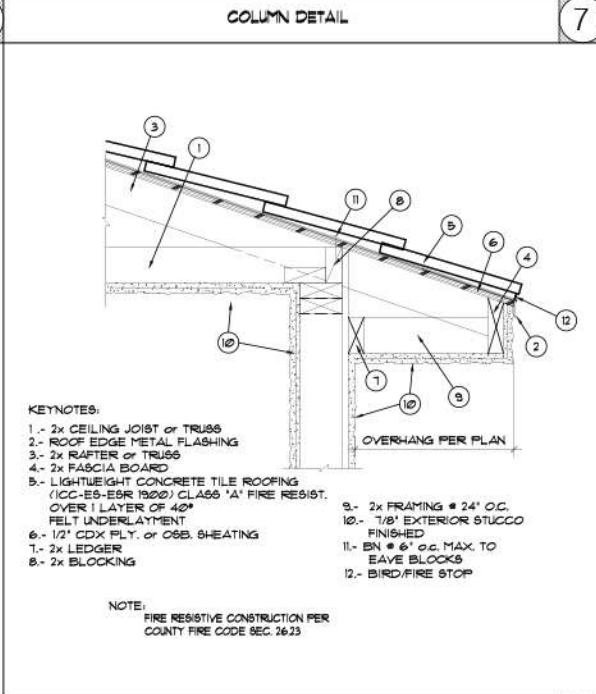

TYP. SHEARWALL DETAIL

12

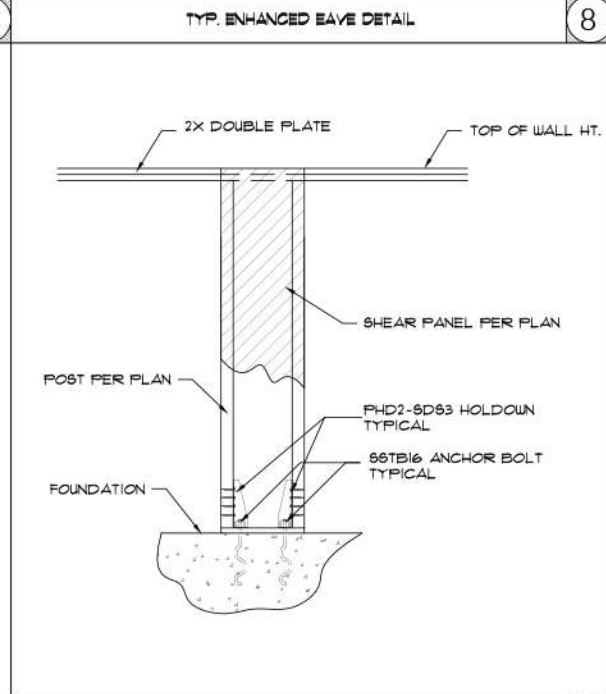

TYP. SHEARWALL DETAIL

13

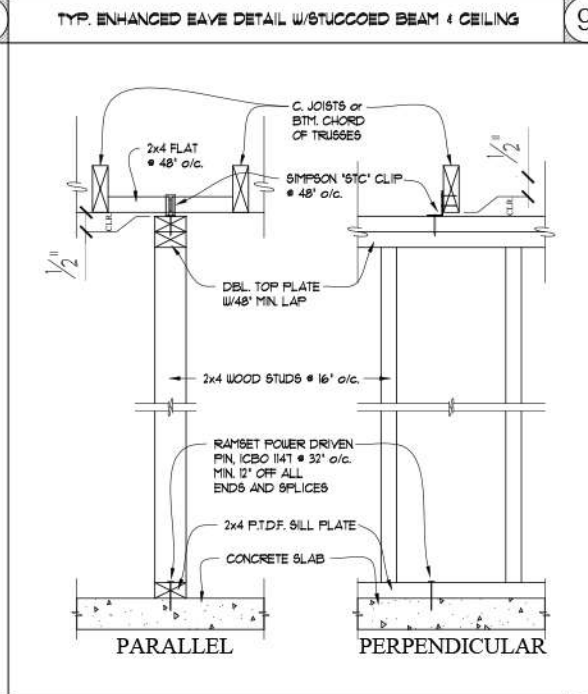

PARTITION WALL DETAIL

14

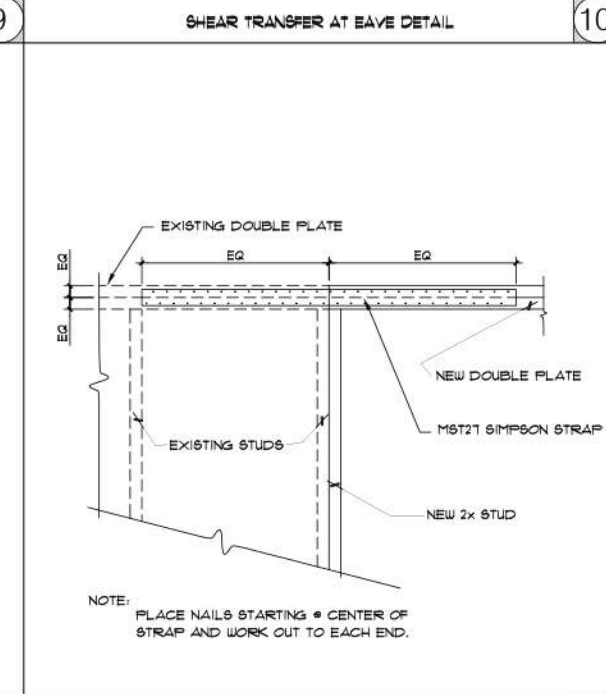

M571 STRAP AT NEW WITH EXISTING

15

MAR-Co.
 HOUSE PLANS & DESIGNS
 PLANS-DRAWING-DESIGN-3D-PERMISS
 MARCO A. LAUREANO
 11111 N. 111th Ave. Suite 100
 Scottsdale, AZ 85259
 WWW.MARCOHOUSEPLANS.COM
 760-941-5978

MAR-Co.
 HOUSE PLANS & DESIGNS
 PLANS-DRAWING-DESIGN-3D-PERMISS
 MARCO A. LAUREANO
 11111 N. 111th Ave. Suite 100
 Scottsdale, AZ 85259
 WWW.MARCOHOUSEPLANS.COM
 760-941-5978

OWNERS NAME & ADDRESS:
MR. & MRS. GARCIA
 XXXX HOMESTEAD DR. SAN MARCOS, CA. 92069

PROJECT NAME & ADDRESS:
GARCIA'S HOUSE REMODEL
 XXXX HOMESTEAD DR. SAN MARCOS, CA. 92069

CONSULTANT:
 MARCO A. LAUREANO

REVISIONS:

DATE: 09/04/2012
 SCALE: AS SPECIFIED
 DRAWN & PREPARED BY: MARCO A. LAUREANO

SHEET: D-1
 OF: 9