

GARAGE ROOF FRAMING PLAN

SCALE: 1/4" = 1'

FRAMING NOTES:

- 1) EACH TRUSS SHALL BE LEGIBLY BRANDED, MARKED OR OTHERWISE HAVE PERMANENTLY AFFIXED THEREON THE FOLLOWING INFORMATION LOCATED WITHIN 2 FEET OF THE CENTER OF THE SPAN ON THE FACE OF THE BOTTOM CHORD:
 - IDENTITY OF THE COMPANY MANUFACTURING THE TRUSS
 - THE DESIGN LOAD
 - THE SPACING OF THE TRUSSES
- 2) ALL SHEAR PANELS MUST EXTEND TO THE ROOF

ROOF DIAPHRAGM

- (A) BLOCKED 5/32 SHEATHING WITH 8d COMMON NAILS # 4" O.C. BOUNDARY / 6" O.C. EDGES / 12" O.C. FIELD
- (B) BLOCKED 5/32 SHEATHING WITH 8d COMMON NAILS # 6" O.C. BOUNDARY / 6" O.C. EDGES / 12" O.C. FIELD
- (C) BLOCKED 5/32 SHEATHING WITH 8d COMMON NAILS # 6" O.C. ALL EDGES / 12" O.C. FIELD

IGNITION-RESISTANT CONSTRUCTION NOTES:

- 1) WALLS, EXTERIOR WALL SURFACES SHALL BE NON-COMBUSTIBLE (STUCCO, MASONRY, CEMENT FIBER BOARD, ETC.) IGNITION-RESISTANT, HEAVY TIMBER OR LOG WALL CONSTRUCTION (COUNTY BUILDING CODE 1044.33)
- 2) EAVES, SOFFITS AND FASCIAS SHALL BE CONSTRUCTED IN CONFORMANCE WITH GUIDANCE DOCUMENT DP11 #98 (COUNTY BUILDING CODE 1044.23)
- 3) UNENCLOSED UNDERFLOOR, UNDERFLOOR AREAS SHALL BE ENCLOSED TO THE GROUND WITH NON-COMBUSTIBLE OR IGNITION-RESISTANT WALLS (COUNTY BUILDING CODE 1044.42)
- 4) VENTS: VENTS ARE NOT PERMITTED IN OVERHANG AREAS. VENTS SHALL RESIST THE INTRUSION OF FLAMES AND ASPERBS OR SHALL BE PROTECTED BY LOUVERS AND J-NCH NON-COMBUSTIBLE, CORROSION-RESISTANT METAL MESH (COUNTY BUILDING CODE 1044.21 & 1044.33)
- 5) GLAZING: EXTERIOR WINDOWS, WINDOWS, GLAZED DOORS, AND GLAZED OPENINGS WITHIN DOORS SHALL BE DUAL-GLAZED UNITS WITH A MINIMUM OF ONE TEMPERED PANE OR SHALL BE GLASS BLOCK UNITS OR SHALL HAVE A FIRE-RESISTANCE RATING OF NOT LESS THAN 20 MINUTES. GLAZING FRAMES MADE OF VINYL SHALL HAVE WELDED CORNERS AND METAL REINFORCEMENT IN THE INTERLOCK AREA (COUNTY BUILDING CODE 1044.32)
- 6) SKYLIGHTS: SKYLIGHTS SHALL BE TEMPERED GLASS (COUNTY BUILDING CODE 1044.16)
- 7) ROOF GUTTERS: ROOF GUTTERS SHALL BE PROVIDED WITH THE MEANS TO PREVENT THE ACCUMULATION OF LEAVES AND DEBRIS IN THE GUTTER (COUNTY BUILDING CODE 1044.15)
- 8) EXTERIOR DOORS: EXTERIOR DOORS SHALL BE APPROVED IGNITION-RESISTANT CONSTRUCTION, SOLID-CORE WOOD NOT LESS THAN 1" THICK, OR HAVE FIRE PROTECTION RATING OF NOT LESS THAN 20 MINUTES (COUNTY BUILDING CODE 1044.32)
- 9) DECKING AND OTHER BUILDING APPENDAGES: EXTERIOR BALCONIES, CARPORTS, DECKS (PATIO COVERS, UNENCLOSED ROOFS AND FLOORS AND SIMILAR ARCHITECTURAL APPENDAGES AND PROJECTIONS SHALL BE CONSTRUCTED AS FOLLOWS (COUNTY BUILDING CODE 1044.41)
 - NON-COMBUSTIBLE CONSTRUCTION (SUCH AS CONCRETE OR METAL)
 - FIRE-RETARDANT TREATED WOOD (PRESSURE-TREATED WITH FIRE RETARDANT, LISTED FOR EXTERIOR USE, INSTALLED PER LISTING)
 - HEAVY TIMBER CONSTRUCTION (MINIMUM DIMENSIONS 3X DECKING, 6x6 COLUMNS, 4x6 OR 6x8 BEAMS, 4x8 JOISTS)
 - ONE-HOUR FIRE-RESISTIVE CONSTRUCTION (THE COUNTY WILL ALSO ACCEPT DECKS WITH A NON-COMBUSTIBLE SURFACE SUCH AS CERAMIC TILES, OR A DECK SURFACE LISTED BY APPROVED EVALUATION SERVICE AS "ONE-HOUR" OR AS A CLASS 'A' ROOF COVERING. ALL OTHER EXPOSED SURFACES MUST BE ENCLOSED WITH IGNITION-RESISTANT MATERIALS SUCH AS STUCCO OR CEMENT FIBER MATERIAL. THERE IS NO FIRE-RESISTIVE REQUIREMENTS FOR HANDRAILS AND BALUSTERS
- 10) FENCES AND OTHER ATTACHMENTS: THE FIRST FIVE FEET OF FENCES AND OTHER ITEMS ATTACHED TO A STRUCTURE SHALL BE CONSTRUCTED OF NON-COMBUSTIBLE MATERIAL OR MEET THE SAME FIRE-RESISTIVE STANDARDS AS THE EXTERIOR WALLS OF THE STRUCTURE (COUNTY BUILDING CODE 1044.1)
- 11) SPARK ARRESTERS: ALL STRUCTURES HAVING A CHIMNEY, FLUE, OR STOVEPIPE ATTACHED TO A FIREPLACE, STOVE, BARBECUE, OR OTHER SOLID OR LIQUID FUEL BURNING EQUIPMENT OR DEVICE SHALL HAVE THE CHIMNEY, FLUE OR STOVEPIPE EQUIPPED WITH AN APPROVED SPARK ARRESTER. SPARK ARRESTERS SHALL BE CONSTRUCTED OF WELDED OR WOVEN WIRE MESH 1/2 GAUGE THICKNESS OR LARGER, WITH OPENINGS NO GREATER THAN 1/2" OR OTHER MATERIAL FOUND SATISFACTORY BY THE FIRE MARSHAL (COUNTY FIRE CODE 6014.6)
- 12) ROOFING: ROOFING SHALL HAVE A MINIMUM CLASS 'A' FIRE RATING FOR ROOF COVERINGS WHERE THE PROFILE ALLOWS A SPACE BETWEEN THE ROOF COVERING AND THE ROOF DECKING, THE SPACE AT THE EAVE ENDS SHALL BE FIRE STOPPED TO PRECLUDE ENTRY OF FLAMES OR EMBERS (COUNTY BUILDING CODE 1044.2)

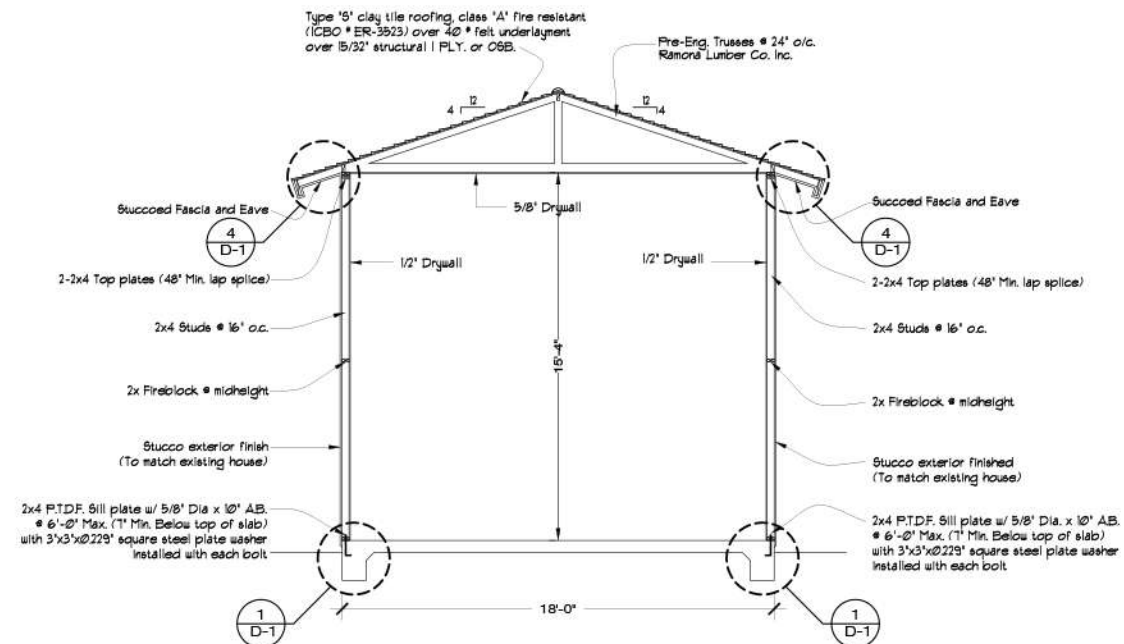

SECTION A

SCALE: 1/4" = 1'

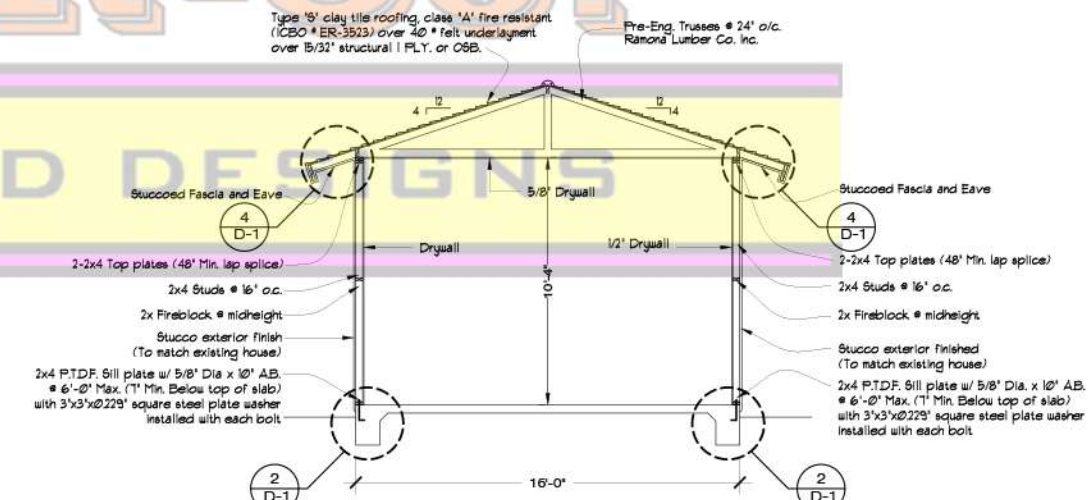

SECTION B

SCALE: 1/4" = 1'

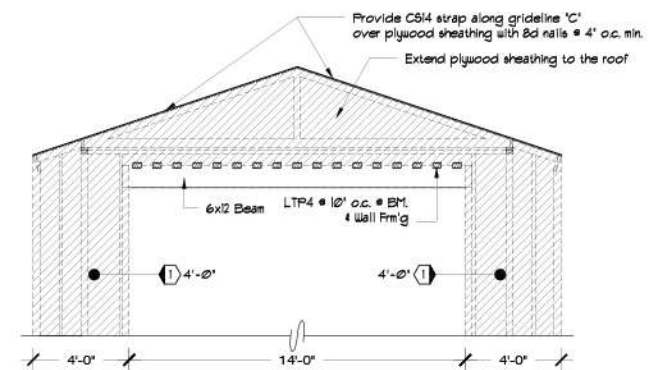

Shear transfer @ garage door opening

SCALE: 1/4" = 1'

MAR-CO.
 HOUSE PLANS & DESIGNS
 PLANS DRAFTING DESIGN 3D-BUILDING PERMITS
 MARCO A. LAUREANO
 LICENSE: 16968
 760-805-2338
 WWW.MARCOHOUSEPLANS.COM

MAR-CO.
 HOUSE PLANS & DESIGNS
 PLANS DRAFTING DESIGN 3D-BUILDING PERMITS
 MARCO A. LAUREANO
 LICENSE: 16968
 760-805-2338
 WWW.MARCOHOUSEPLANS.COM

PROJECT NAME & ADDRESS:
MATES' NEW RV & BOAT GARAGE
 XXXX RYAN DR., ESCONDIDO, CA. 92025

CONSULTANT:

REVISIONS:

DATE: **09/25/2014**

SCALE: AS SPECIFIED

DRAWN & PREPARED BY: MARCO A. LAUREANO

SHEET: **A-3-R**

OF: **11**